



# **ESTABLISHING CIVILIZATION IN THE KLONDIKE GOLD RUSH OF 1896**

MARCH 15th-17th, 2024



# TABLE OF CONTENTS

---

<b>Table of Contents</b> .....	<b>1</b>
<b>MSUMUN Notices</b> .....	<b>2</b>
Committee Content Warning.....	2
MSUMUN Statement on Mental Health.....	4
MSU Provisional Land Acknowledgement.....	5
<b>Rules of Procedure</b> .....	<b>6</b>
Article I: General Rules.....	6
Article II: Meetings.....	6
Article III: Agenda.....	6
Article IV: Conduct of Business.....	7
Article V: Types of Proposals.....	7
Article VI: Voting.....	8
Remaining Points.....	8
A Note on Acceptable Behavior and Conduct.....	9
<b>Letter from the Crisis Director</b> .....	<b>10</b>
<b>Letter from the Chair</b> .....	<b>11</b>
<b>Junior Staff Introductions</b> .....	<b>12</b>
<b>Committee Setting and Power of the Committee</b> .....	<b>14</b>
<b>Alaska and the Yukon</b> .....	<b>15</b>
Local Geography.....	15
Local Fauna.....	15
Local Agriculture.....	17
Economy, Industry, and Finance.....	18
The Business of Prospecting.....	19
Labor Rights.....	21
Entertainment in Dawson City.....	24
<b>Lifescape</b> .....	<b>27</b>
Health.....	27
Law Enforcement.....	29
Crime.....	30
<b>Journey to the Klondike</b> .....	<b>32</b>
Weather and Seasons.....	32
Routes to Dawson City.....	33

**Science, Technology, and Communication..... 34**  
    Building Infrastructure..... 34  
    Technology of the Time..... 35  
    Journalism, Press, and How Information Spreads..... 36  
    Mining Process..... 38

**Sustainability and the Supply Chain..... 40**  
    Rations and the Supply Chain..... 40  
    Transportation..... 42

**Societal, Cultural, and Political Statuses..... 44**  
    Indigenous Peoples..... 44  
        Social Class..... 44  
        The Han..... 44  
        The Tagish..... 45  
        The Tlingit..... 45  
        The Chilkooot..... 46  
        The Tutchone..... 47  
    Women in Boomtowns and Dawson City..... 47  
        Social Class..... 47  
        Occupations..... 48  
        Gender Roles in Klondike..... 48  
        Children and Family..... 49  
        Religion..... 49

**Characters..... 62**

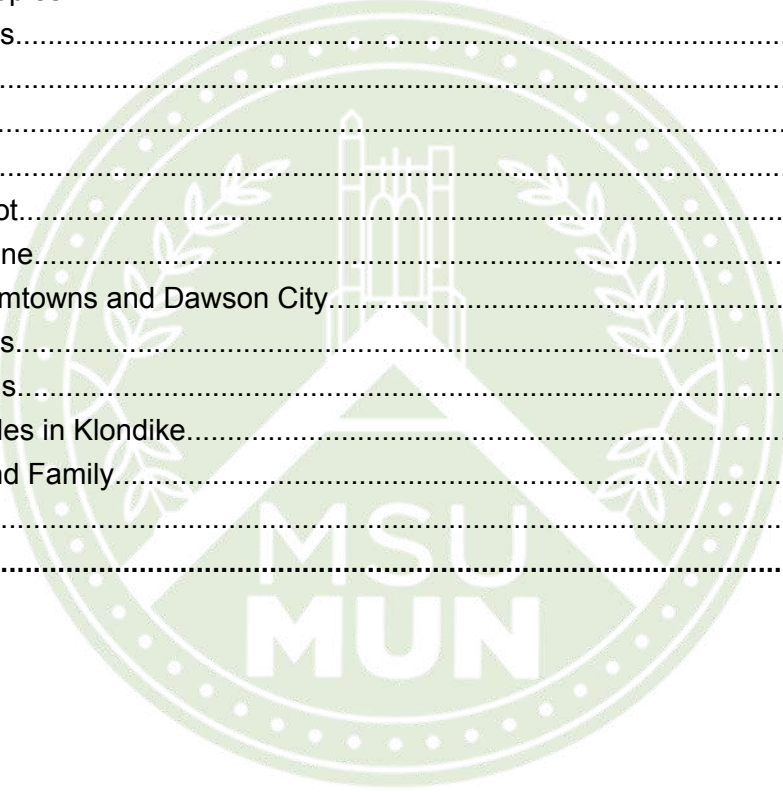

# MSUMUN NOTICES

---

## Committee Content Warning

While MSUMUN values the discussion and awareness of most topics and a delegate's obligation to accurately represent their assigned role, all participants who engage in any bigoted, racist, sexist, homophobic, ableist, fatphobic, xenophobic, or other such comments or sentiments will be subject to appropriate disciplinary action at the discretion of MSUMUN's Secretariat. Additionally, in all things, MSUMUN pledges its Secretariat and staff to maintain approachability and inclusivity; if any participant has any questions, comments, or concerns they are encouraged to contact MSUMUN's Secretariat or, in the case of delegates, its staff. If you have questions or concerns regarding this, please reach out to your committee's senior staff before conference weekend.

Red Cedar University Model United Nations (MSUMUN) is committed to fostering a safe and secure environment for all delegates, staff, and advisors. In this, MSUMUN operates with a zero-tolerance policy concerning any and all instances of harassment and discrimination. Further, MSUMUN is committed to promoting the mental health of its participants and requires all participants to act with compassion, grace, and understanding. MSUMUN encourages participants to step out of their committee room and/or speak with a trusted individual if they are feeling overwhelmed or are otherwise uncomfortable.

All participants should be aware that MSUMUN's Secretariat and staff are designated mandatory reporters with MSU's Office of Institutional Equity while operating within their roles before and during the conference.



## MSUMUN Statement on Mental Health

*Michigan State University Model United Nations* is committed to fostering a safe and secure environment for all delegates, staff, and advisors. In this, MSUMUN operates with a zero tolerance policy with regard to any and all instances of harassment and discrimination. Further, MSUMUN is committed to promoting the mental health of its participants and requires all participants to act with compassion, grace, and understanding. MSUMUN encourages participants to step out of their committee room and/or speak with a trusted individual if they are feeling overwhelmed or are otherwise uncomfortable.

Moreover, MSUMUN recognizes that some of its committees may include references to or discussions of sensitive topics. While RCMU values the discussion and awareness of these topics and a delegate's obligation to accurately represent their assigned role, all participants who engage in any bigoted, racist, sexist, homophobic, ableist, or other such comments or sentiments will be subject to appropriate disciplinary action at the discretion of MSUMUN's Secretariat. Additionally, in all things, MSUMUN pledges its Secretariat and staff to maintain approachability and inclusivity; if any participant has any questions, comments, or concerns they are encouraged to contact MSUMUN's Secretariat or, in the case of delegates, its staff.

All participants should be aware that MSUMUN's Secretariat and staff are designated mandatory reporters with MSU's Office of Institutional Equity while operating within their roles before and during the conference.

## MSU Provisional Land Acknowledgement

“We collectively acknowledge that Michigan State University occupies the ancestral, traditional, and contemporary Lands of the Anishinaabeg – Three Fires Confederacy of Ojibwe, Odawa, and Potawatomi peoples. In particular, the University resides on Land ceded in the 1819 Treaty of Saginaw. We recognize, support, and advocate for the sovereignty of Michigan’s twelve federally-recognized Indian nations, for historic Indigenous communities in Michigan, for Indigenous individuals and communities who live here now, and for those who were forcibly removed from their Homelands. By offering this Land Acknowledgement, we affirm Indigenous sovereignty and will work to hold Michigan State University more accountable to the needs of American Indian and Indigenous peoples.”<sup>1</sup>



---

<sup>1</sup> “Land Acknowledgement,” American Indian and Indigenous Studies, accessed December 5, 2021, <https://aiis.msu.edu/land/>.

# RULES OF PROCEDURE

---

## Article I: General Rules

1. Delegates are expected to adhere to all regular MSUMUN XXIII rules and standards of decorum.
2. In the event of a dispute over the Rules of Procedure, either those of MSUMUN generally or the Klondike Gold Rush committee, the MSUMUN Secretariat will be the ultimate authority of appeal.

## Article II: Meetings

1. All of the Klondike Gold Rush committee meetings shall be attended by all specified members of the committee, unless otherwise authorized by the MSUMUN Secretariat.
2. Unless otherwise indicated by the MSUMUN Secretariat or the Klondike Gold Rush committee staff, all meetings of the committee will be held in the specified the Klondike Gold Rush committee room as designated by MSUMUN.

## Article III: Agenda

1. Items for debate may be pulled from the background guide, but are not limited to what is explicitly mentioned. Staff would like to see well-rounded and well-researched delegates bring new and relevant topics to the table.



2. Any Committee member may make a motion to restrict debate to one topic. If this motion passes, debate shall be limited to the topic specified until such time as another motion is made to either change the topic under consideration or return to general debate.
3. The Agenda is to be set at the beginning of committee, formal debate on committee topics may not begin until the Agenda has been set.
4. A Speaker's List may be opened at any time when motions are being entertained.  
Additionally, a delegate may request to be added to the Speaker's List at any time. If the Chair is not actively calling for speakers to be added, a delegate may send a note to the dias.

#### **Article IV: Conduct of Business**

1. the Klondike Gold Rush committee proceedings shall be conducted in the form of a permanent Moderated Caucus until such a time that a committee member makes a motion to change this.

#### **Article V: Types of Proposals**

1. Directive: A directive requires only one sponsor, though it may have more. The number of required signatories is up to the discretion of the Chair. A committee member need only move to introduce a directive in order for it to be considered by the entire committee.
2. Press Releases: A press release is usually passed in lieu of a directive if doing so is more likely to make the committee's intentions clear. A press release is written either in the form of a directive or a press release; it requires the same number of sponsors and signatories as a directive.

3. Communiques: A communique is an external communication from the entire committee with a non-committee member. Such a communication can include anything from a request of support to negotiations to even a threat. Passing this type of document can also result in the person being contacted meeting with the committee if requested.

### **Article VI: Voting**

1. Votes may be entered as For, Against, or Abstentions.
2. Any delegate who designates themselves as “Present and Voting” during roll call may not abstain on any matter.
3. Votes on non-substantive proposals or procedural matters will be passed by the affirmative vote of a simple majority of committee members. Abstentions are allowed on non-substantive proposals, but not procedural matters.
4. Votes on substantive matters will be passed by the affirmative vote of a simple majority of committee members.
5. In all cases, a simple majority constitutes more than half of the For and Against votes.

### **Remaining Points**

1. Any rules and regulations are subject to change at the discretion of the Chair.
2. If you have additional questions, please visit the [MSUMUN Website](#)

### **A Note on Acceptable Behavior and Conduct**

While the Klondike Gold Rush of 1896 takes place over 100 years ago, your character will be held to the standards of appropriateness prevalent to today. Any inappropriate language, conduct, behavior, etc. found in crisis notes, directives, in-room speeches, and any other committee-related matters will not be tolerated. Delegates who engage in this behavior will forfeit their eligibility for MSUMUN awards and will be reported to the Secretariat of MSUMUN.



## LETTER FROM THE CRISIS DIRECTOR

Hi Delegates,

I am Alex Opalikhin (she/they), and I have the wonderful pleasure to be the crisis director of the Klondike Gold Rush of 1896 committee! Last year was my first year at MSUMUN, in which I was a Junior Staffer for the US Congress and Iron Jawed Angels Joint Crisis Committee. This year, I've come with a group of wonderful staffers to bring a very unique time and place within history to a Model UN setting and invite you all to experience this setting with all of us.

I am an International Relations and Comparative Cultures & Politics double major at James Madison College within Michigan State. As you can tell, I adore discussing politics and the roles different people play within a political setting. I live around Novi, MI, and went to high school at International Academy West. Outside of classwork, I busy myself until free time is merely a myth of a bygone era. I travel with MSU's competitive Model UN team, MSUIRO, I am very passionate about music and theater, and I do advocacy work on campus on behalf of PRISM and Transaction, two LGBTQ+ caucuses dedicated to providing support and advocating for LGBTQ+ students on campus.

I first became interested in the Klondike Gold Rush due to the tangential relationship it has with the mass movements of people. It is fascinating to examine the paths people take to achieve success, the stories of the prospectors working to gain a fortune, and the stories of the citizens in these areas making a new life for them in the inhospitable conditions of Alaska and the Yukon. I am so proud of my staffers for working together to bring this committee to life, and am so excited for all of you to be a part of this committee. Gold is where you find it, delegates!

*Best Regards,*

*Alex Opalikhin*

## LETTER FROM THE CHAIR

Hello Delegates,

My name is Christian Allmand (he/him), and it is my pleasure to be the chair of the Klondike Gold Rush of 1896 this year! Last year was my first year at MSUMUN, where I was a junior staffer for the US Congress Joint Crisis Committee. This year, I have had the privilege to work with an incredibly talented group of staffers who have worked tirelessly to make this background guide as best as possible.

I am a sophomore at MSU majoring in Supply Chain Management at the Eli Broad College of Business. However, don't let my degree in business make you think that I do not care for social sciences; it is actually my favorite topic to study. I also come from Canton, MI, which is in between Ann Arbor and Detroit, and I went to P-CEP for high school. Outside of school, I enjoy reading books (especially fiction books such as The Lord of the Rings), playing games like Civilization VI and Factorio, listening to music from bands like Nirvana and Talking Heads, and playing hide and seek with my cat Piper.

I am very proud of what our committee has done to prepare delegates for the Klondike Gold Rush. I sincerely hope you all enjoy what we have written for you and have a great time making this background guide come to life.

Best Regards,

Christian Allmand

## JUNIOR STAFF INTRODUCTIONS

### ***Bethany Detwiler***

Heyo! My name is Bethany (or Beth) (she/her), and I am a junior staffer for this year's Klondike Gold Rush Committee. I am a freshman in the College of Engineering, and I plan on majoring in Computer Science. My hometown is an hour and a half drive east of East Lansing, Lake Orion, MI. Before Entering college, I played clarinet in my high school marching band. Outside of Model United Nations, you can find me reading, biking, and birdwatching. I am also on MSU's Underwater Hockey team. I am incredibly excited about this committee and am looking forward to seeing you all at MSUMUN!

### ***Arya Sharma***

Hi, I'm Arya (He/Him)! I'm a freshman at MSU majoring in psychology, hoping to head to medical school when all is said and done to be a psychiatrist. I'm from Canton, Michigan, and I attended PCEP. My home school was Salem, and I never had a class in Canton. I love anything creative, from writing to drawing to painting to reading. I'm so excited to see what everyone will come up with during this committee, and I hope you have fun!

### ***Joyce Peterlin***

What is up, party people? My name is Joyce (she/her) and I am a freshman at the James Madison College, intending to major in International Relations and Social Relations & Policy, with minors in Public Relations and Russian. Before I was your super cool junior staffer, I was an MSUMUN delegate just like you! I participated in the Germanic Tribes committee in 2022

and the SpaceX Board of Directors in 2023. I went to Stoney Creek High School in Rochester Hills, MI. Outside of MSUMUN, I am an active member of MSU International Relations Organization, MSU's competitive Model UN team. I am also a long-time Dungeons & Dragons player and DM, going on 5-ish years now. I hope you all have a fun time with this committee, and I can't wait to see your creative solutions!

***Hannah Magnus***

Greetings from afar! My name is Hannah (she/her) and I am a freshman at MSU majoring in arts and humanities at the residential college with a double major in anthropology. I am originally from the Chicago suburbs, but I moved to Michigan during my sophomore year of high school, where I participated in Model UN for two years. Away from MUN, I enjoy working in MSU's archaeology lab, and when at home, I like to eat baked brie and watch movies with my three dogs and two lovely but annoying younger brothers.

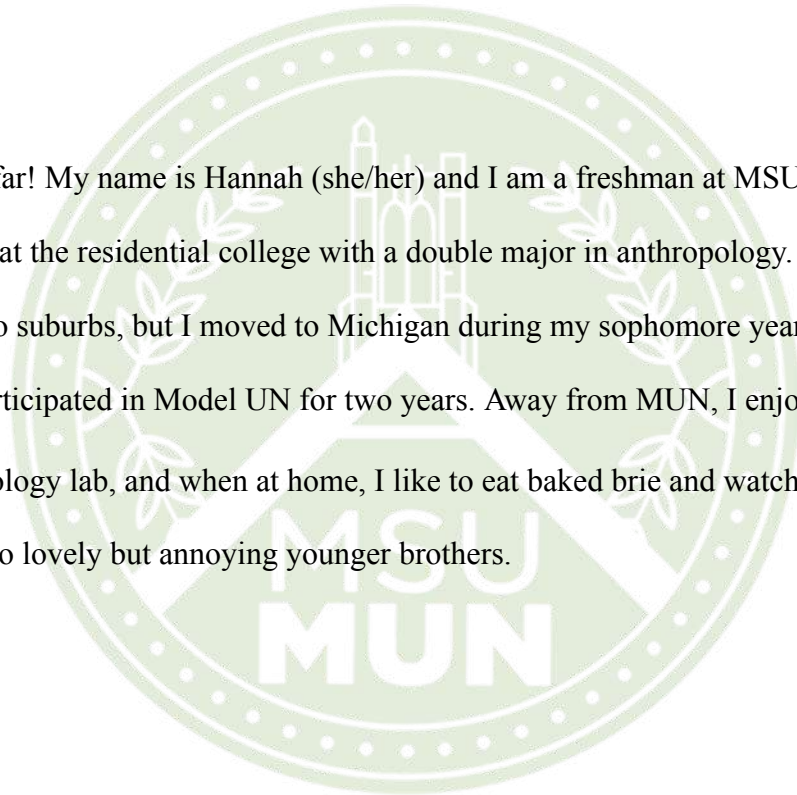

## COMMITTEE SETTING AND POWER OF THE COMMITTEE

The committee “Establishing Civilization in the Klondike Gold Rush of 1896” is set in the town of Dawson City, located in the modern-day Yukon territory of Canada. The committee begins at the end of 1896 in the winter and elapses over the course of several seasons (beginning with winter, then moving on to spring, summer, autumn, winter, etc.). As a delegate, you will meet at the city's “town hall” where you will decide what actions need to be taken to provide Dawson City the opportunity to thrive. The residents of Dawson City elected each character to represent their overall interests. As such, each character has a focus they intend to develop, but will all work together to benefit the interests of the town.

As part of the colloquially known “Dawson City Planning Committee”, the delegates, with the directives they pass, do have legitimate power in the town, and citizens will be inclined to adhere to the directives of the Planning Committee. This is assisted due to the presence of state government officials within the committee. The citizens of Dawson City may not like every directive passed by the committee, and if the wants of the people are not heard, there may be opposition to the Planning Committee. During the committee, delegates will be challenged with obstacles such as natural disasters, economic hardships, famine, disease, fires, maintaining public support, and more that will need to be resolved for Dawson City to grow. Many delegates will have different perspectives on which challenge to confront first or which initiative gets the top priority (for example, a business person may put economic development and industrialization efforts over addressing the current disease outbreaks, while the town doctor may have the opposite opinion) so delegates must make compromises and settlements to promote the development and well-being of the city.



# ALASKA AND THE YUKON

## Local Geography

Dawson City is in the middle of the Yukon, a region in Northwest Canada. It resides at the junction of the Klondike and Yukon rivers.<sup>2</sup> The Yukon River can be seen from the western edge of the city, though it is on the east bank of the river.<sup>3</sup> It is surrounded by mountains; however, the city itself is flat. Surrounding the area, there are three main types of terrain: mountains, plateaus, and coastal tundra. The area outside of Dawson City is also very forested.<sup>4</sup> Dawson City resides on a fault, which has created a trench from which lava flows may occasionally happen. All in all, floods and landslides are certainly not unheard of.<sup>5</sup>

## Local Fauna

Because of the diversity in climate, there are several types of fauna near Dawson City. There are many herbivores in the area such as mountain sheep, deer, hares, and squirrels.<sup>6</sup> These animals can serve as potential local food sources for humans, but with Dawson City's rapidly

---

<sup>2</sup> The Editors of Encyclopaedia Britannica, "Dawson," Britannica, Encyclopaedia Britannica, last modified October 23, 2023, <https://www.britannica.com/place/Dawson-Yukon>.

<sup>3</sup> Hal Guest, "Dawson," The Canadian Encyclopedia, Historica Canada, March 4, 2015, <https://www.thecanadianencyclopedia.ca/en/article/dawson>.

<sup>4</sup> "Dawson: Physical Geography," Dawson City, accessed October 20, 2023, <https://meiradawsoncity.weebly.com/chapter-2-physical-geography.html>.

<sup>5</sup> Venessa Benne, Maurice Colpron, and Mike Burke, "Current Thinking on Dawson Range Tectonics and Metallogeny," EMR Library, Government of Canada, July, 2010, <https://emrlibrary.gov.yk.ca/ygs/MR/MR-2/Current%20thinking%20on%20Dawson%20Range%20Tectonics%20and%20Metallogeny.pdf>.

<sup>6</sup> "Yukon Wildlife Information," Dawson City River Hostel, Yukon Hostels, accessed October 20, 2023, [https://www.yukonhostels.com/new\\_wildlife.html](https://www.yukonhostels.com/new_wildlife.html).

growing population and lax hunting laws, overhunting is an incredible risk.<sup>7</sup> Mountain sheep may be more difficult to come across, residing mostly on higher elevations with rocky cliffs.<sup>8</sup> Moose also roam the forests, the large, majestic creatures often appearing seemingly out of nowhere. At six feet and 1400 pounds on average, moose can be aggressive and even lethal, especially regarding mothers with their young or moose feeling threatened.<sup>9</sup> They can be found closer to river banks alongside grizzly bears.<sup>10</sup> Their smaller cousins, caribou, can be seen traveling in packs, and tend to be migratory and less aggressive.<sup>11</sup> Foxes can be seen hunting more in the grass, though they are significantly more frightened of humans and rarely attack.<sup>12</sup>

Animal attacks are a frequent occurrence in Klondike life. Grizzly and black bears, cougars, and wolves roam the forests around Dawson City. While Grizzly bears might be more likely to leave one alone, Black bears are more curious, but both can become problematic when they smell food. Both types of bears are good swimmers and like to climb or even uproot small trees. Grizzlies will be concentrated by rivers in the spring and fall due to their primary food sources being by the water. Cougars, swift and silent hunters, are one of the most common culprits of animal attacks, and especially target children, as they make easy prey.<sup>13</sup> Wolves hunt in packs and communicate amongst themselves through their distinctive howls, but become a major

---

<sup>7</sup>“Environmental Consequences of the Gold Rush - Klondike Gold Rush National Historical Park (U.S.” 2018. National Park Service. <https://www.nps.gov/klgo/learn/historyculture/environmental-impacts.htm>.

<sup>8</sup> “Mountain Sheep,” Hinterland Who’s Who, Canadian Wildlife Federation, accessed October 20, 2023, <https://www.hww.ca/en/wildlife/mammals/mountain-sheep.html>.

<sup>9</sup> “Fun With Flora and Fauna,” Dawson City, Klondike Visitors Association, accessed October 20, 2023, <https://dawsoncity.ca/flora-fauna/>.

<sup>10</sup> Dawson City River Hostel, “Wildlife.”

<sup>11</sup> AZ Animals Staff, “Caribou: Rangifer Tarandus,” AZ Animals, Flywheel Publishing, last modified April 4, 2023, <https://a-z-animals.com/animals/caribou/>.

<sup>12</sup> Dawson City, “Flora and Fauna.”

<sup>13</sup> Dawson City River Hostel, “Wildlife.”

issue for humans due to their territorial nature.<sup>14</sup> Skunks, raccoons, and porcupines can also be found, but serve little danger compared to the other predators of the region. There is a rich fish population, including salmon, grayling, and burbot, but fish populations rely on the health of the river they are in, so utilizing fish as a food source must also work to ensure clean source rivers.<sup>15</sup>

## Local Agriculture

It is incredibly difficult for crops to survive in permafrost due to root damage and instability.<sup>16</sup> As such, one may find themselves relying heavily on natural, wild resources, which can provide both nutrition and mild medical relief.<sup>17</sup> Lambsquarter, a common weed, can be eaten like spinach.<sup>18</sup> There are also many types of berries, such as cranberries, Saskatoon berries, Haskap berries, and Black Currents. Some several roots and plants are edible, such as stinging nettle, dandelion,<sup>19</sup> bear root, and rhubarb. In terms of crops, beetroots, potatoes, carrots, onion, garlic, cabbage, and turnips are likely to be one's most successful crop.<sup>20</sup>

Crops grown in the Yukon must be hearty and able to withstand the hard environment, and if agriculture is to be pursued in greater amounts, infrastructure to allow for farmland must also

<sup>14</sup> “Wolf,” Hinterland Who’s Who, Canadian Wildlife Federation, accessed October 20, 2023, <https://www.hww.ca/en/wildlife/mammals/wolf.html>.

<sup>15</sup> “Fish, Amphibians, Reptiles,” Hinterland Who’s Who, Canadian Wildlife Federation, accessed October 20, 2023, <https://www.hww.ca/en/wildlife/fish-amphibians-and-reptiles/>.

<sup>16</sup> Futurum. 2023. “Farming on permafrost - Futurum.” Futurum Careers. <https://futurumcareers.com/farming-on-permafrost>.

<sup>17</sup> Konrad Taube, “Backcountry Uses for Medicinal and Edible Plants of the Yukon,” Wilderness Classroom, accessed October 20, 2023, <https://wildernessclassroom.org/backcountry-uses-for-medicinal-and-edible-plants-of-the-yukon/>.

<sup>18</sup> “Common Lambsquarters Science Page,” United States Botanic Garden, Cornell University, accessed October 20, 2023, <https://www.usbg.gov/sites/default/files/images/lambsquarter.pdf>.

<sup>19</sup> “Wild Edible Plants of Yukon,” Northern Bushcraft, accessed October 20, 2023, [https://www.northernbushcraft.com/guide.php?ctgy=edible\\_plants&region=yt](https://www.northernbushcraft.com/guide.php?ctgy=edible_plants&region=yt).

<sup>20</sup> “Yukon Territory Food and Drink,” World Travel Guide, Columbus Travel Media Ltd., accessed October 20, 2023, <https://www.worldtravelguide.net/guides/north-america/canada/yukon-territory/food-and-drink/>; “Traditional Plants Community Info Session in Dawson City,” First We Eat, April 15, 2017, <https://firstweeat.ca/2017/04/15/traditional-plants-community-info-session-in-dawson-city/>.

exist. There are examples in Skagway, a neighboring boom town in Alaska, that has been able to utilize farming effectively as a means of self-sufficiency. Skagway benefits from longer summers and less rain, allowing the soil to be less acidic.<sup>21</sup> For Dawson City's residents to utilize agriculture as a prolific resource, either new feasible farmland should be found that mimics conditions of Skagway's farmland, or infrastructure development should be used to turn existing nearby acidic soil into fertile farmland. Looking into existing soil treatment methods of the time can assist greatly in this endeavor.

## **Economy, Industry, and Finance**

### ***Gold Standard and Economic Background***

In 1897, the United States, Canada, and many other countries operated under a Gold currency standard. The Gold Standard was a system in which countries would fix the value of their currencies to a set amount of gold, additionally allowing exchange rates between countries using the Gold Standard to be fixed as well.<sup>22</sup> Other forms of monetary currency, such as bills and silver, existed, but the value of these currencies was all fixed around a specific amount of gold. Gold was chosen not only due to its ancient history as a valuable commodity but also due to its practicality as a currency. Gold is very durable, long-lasting, and can be stored easily in ingot form, allowing it to be an effective form of money.<sup>23</sup>

Canada and the United States have followed the Gold Standard for decades before the Klondike Gold Rush. The Coinage Act of 1873 transitioned the United States toward a full Gold

---

<sup>21</sup> "Gardening in Skagway (U.S. National Park Service)." National Parks Service. Accessed January 5, 2024. <https://www.nps.gov/articles/klgo-skagway-gardening.htm>.

<sup>22</sup> "The Gold Standard System." Gold Industry & Corporate. Accessed October 24, 2023. <https://www.gold.org/history-gold/the-classical-gold-standard>.

<sup>23</sup> Hawtrey, R. G. "The Gold Standard." *The Economic Journal* 29, no. 116 (1919): 428–42. <https://doi.org/10.2307/2223352>. Pgs. 429-430.

Standard and away from silver.<sup>24</sup> Canada's Currency Act in 1854 established the Dominion to follow the Gold Standard as well.<sup>25</sup> Many critics in the United States were concerned with the new monometallism (instead of the previous bimetal standard of gold and silver), believing that the new economic system would lead to unstable prices and a lower amount of money.<sup>26</sup> These criticisms seemed fulfilled come the Depression of 1893, and the continuation of this depression in 1896, soon before the Klondike Gold Rush. The depression was blamed on lingering deflation from the Civil War, underconsumption, and other causes.<sup>27</sup> A consequence of this depression was the desire for more gold to alleviate the recession, and the Klondike Gold Rush solved this issue, providing another very attractive reason for the adventurous to journey to the Yukon and claim the gold for themselves.

### The Business of Prospecting

On the Klondike, a successful mining operation was difficult and expensive. As gold panning did not produce an efficient amount of gold, other more industrialized methods were used (see Science, Technology, and Communication section). Despite the difficulties beyond prospecting in the Klondike, the amount of gold in the region was far larger than the likes of California or South Africa, providing yet another reason for ambitious prospectors to venture to the region.<sup>28</sup>

---

<sup>24</sup> Hayes, Adam. "Crime of 1873." Investopedia, September 15, 2022.

<https://www.investopedia.com/terms/c/crime-1873.asp#:~:text=The%20Coinage%20Act%20of%201873,silver%20ollar%20was%20not%20included.>

<sup>25</sup> Powell, James. *A History of the Canadian Dollar*. Ottawa: Bank of Canada, 2005. Pg. 33.

<sup>26</sup> Hayes, Adam. "Crime of 1873."

<sup>27</sup> Whitten, David O. "The Depression of 1893." EH.net, August 14, 2001.

<https://eh.net/encyclopedia/the-depression-of-1893/#:~:text=By%201890%2C%20the%20US%20economy,produced%20in%20manufacturing%20and%20mining.>

<sup>28</sup> Winslow, Kathryn. *Big Pan-Out: The Klondike Story*. London: Travel Book Club, 1953. Pg. 236.

There were legal barriers that one had to overcome to begin their operation, however. First, a license had to be obtained to be allowed to mine, with Dawson being a primary spot for obtaining them. Miners then had to prospect for a good spot, and once a spot was found, they had to stake the claim, usually by driving physical stakes around the charted territory and returning to Dawson to register the land, which cost \$15 USD.<sup>29</sup> From there, a claim could be mined freely for a year, after which an annual fee of USD 100 had to be paid. Additionally, if a prospector left the claim for a few days, another miner could make a claim on the land.<sup>30</sup> The Canadian government did not give free rein, however, and charged a royalty on the gold taken from a claim, usually between 10 and 20 percent, depending on the amount.<sup>31</sup>

There were disputes on how large the claims could be. At the start of the Rush, claims were generally 150m across a stretch of creek or river. Canadian authorities felt this to be too large and attempted to lower it to 46m, but had to make concessions to miners, and agreed to 76m.<sup>32</sup> Due to different ideas of how much independence a miner could have regarding a prospecting mission, there was often tension between miners and government officials, including figures who worked to settle claim disputes, such as William Ogilvie. Miners were limited to being given one claim by the government; however, there was no limit to how many claims they could buy from other miners.<sup>33</sup> This led to a trend known as enterprise mining.

Prospectors could buy claims that were either “proved” as having gold within them or “unproved” where the presence of gold had not been determined. Unproved claims tended to be

---

<sup>29</sup> Ibid, pg. 183-184.

<sup>30</sup> Allen, W. Douglas. “Information Sharing During the Klondike Gold Rush.” *The Journal of Economic History*, 2005. 1-24. Pg. 9

<sup>31</sup> The Chicago Record (1897). *Klondike. The Chicago Record's Book for Gold Seekers*. Chicago: Chicago Records Co. Pg. 149.

<sup>32</sup> Winslow, Kathryn. *Big Pan-Out: The Klondike Story*. Pg. 181-182.

<sup>33</sup> The Chicago Record (1897). *Klondike. The Chicago Record's Book for Gold Seekers*. Pg. 149.

much cheaper than proved claims, as unproved ones could either yield great results or none.<sup>34</sup>

Additionally, if they had the funds, prospectors could hire others to work for them and mine on their claims for a portion of the profit. One such enterprise miner was Alex McDonald. He would lease the claim given to him by the government to other miners to work the land, earning the majority of profits, while he focussed on amassing further claims through purchase.<sup>35</sup> By the end of 1897, he had amassed 28 claims, earning upwards of 20 million dollars and becoming one of the richest people in the Klondike.<sup>36</sup>

Unfortunately, this practice from enterprise miners led to many smaller miners being destitute. Some sold their equipment and left, while others took manual labor jobs or were hired as miners under richer prospectors. Ultimately, the hope that a new creek with a new flood of gold would be found led a lot of prospectors to stay in the region.<sup>37</sup> Tensions between the rich and the poor prospectors could lead to the common man being driven from the region, and obtaining a balance between these two groups could be a key issue needed to solve.

### Labor Rights

Labor rights were not at the top of the priority list in Klondike. The gold rush fever was very demanding and required long hours of labor that often took up the entire day, and was often a part of the harsh conditions that took the lives of many Klondikers.<sup>38</sup> If they did not lose their lives, then they certainly lost money, as those who did not stake their claim in the land had to

---

<sup>34</sup> Winslow, Kathryn. *Big Pan-Out: The Klondike Story*. Pg. 165.

<sup>35</sup> Berton, Pierre. *Klondike: The Last Great Gold Rush: 1896-1899*. Toronto: McClelland and Stewart, 1974. Pg. 78.

<sup>36</sup> Ibid.

<sup>37</sup> Winslow, Kathryn. *Big Pan-Out: The Klondike Story*. Pg. 173.

<sup>38</sup> "The Klondike Gold Rush." :: The Klondike Gold Rush :: Accessed October 29, 2023. <https://content.lib.washington.edu/extras/goldrush.html>.

work for people who did. These workers' wages were wildly inconsistent, ranging anywhere from \$1-22 per day. The cost of getting to Klondike caused very few workers ever to see a profit. Prospectors could either work for themselves or larger corporations and enterprise miners. Working for oneself ensured a self-made income, but claiming new land for mining was a difficult task. Working for enterprise miners ensured a plot of land to mind, but their income was often chopped up by the entity prospectors worked for.

The bottom line was that in a struggling family, anyone able to hold a pickaxe could be put to work. In most cases, providing and trying to find gold was more important than protecting groups such as children from the hardships of manual labor. No law enforcement had any interest in preventing child labor in Dawson. There were no restrictions on how many hours workers had to look for gold or any safety requirements for employers to follow. These sorts of restrictions or requirements may be important topics for the committee to address.

### ***General Economy of Dawson City***

Economically, Dawson City is the very definition of a Boom Town. Once gold was found in the area, people rushed to Dawson in stampedes. By the winter of 1896, plots of land cost \$500, with that number growing rapidly.<sup>39</sup> One problem the city faces is the massive population influx, so ensuring that affordable housing is open to everyone is certainly an issue on the horizon. Food is also a rapidly emerging issue. At first, food costs, and costs for general materials in Dawson City, were at a higher than average but still feasible number. Joseph Ladue called many of the initial reports detailing that goods in Dawson were expensive “exaggerations” and believed everything to be at a good level.<sup>40</sup> However, this did not last long. Reports now indicate

---

<sup>39</sup> Ibid, 140.

<sup>40</sup> The Chicago Record (1897). *Klondike. The Chicago Record's Book for Gold Seekers*. Chicago: Chicago Records Co. Pg. 266.



that many goods are dramatically more expensive than their original prices. For example, butter seems to be \$5 each as opposed to the previous \$1.50, and an egg now costs \$3.00, when a dozen used to cost \$5.<sup>41</sup> In the face of rising prices, something must be done to ensure the economic stability of the Dawson market.

Additionally, many trees had to be removed to create space for the new residents, and the collected wood was used to build houses and transportation and provide fuel for fireplaces and steamboats. Due to the high wood demand, the lumber industry was massive, and sawmills were quickly established.<sup>42</sup>

The massive numbers of gold coming to and from Dawson encouraged a lavish lifestyle, especially among richer prospectors. Saloons were consistently open and encouraged active drinking and gambling. It was seen as common practice by rich prospectors to spend a grandiose amount of money and spend much of their time gambling or drinking.<sup>43</sup> Some of the earliest slot machines come from Boom Towns in the Gold Rush.<sup>44</sup> At the poker table, there was a culture of high-stakes betting, additionally alienating the prospectors who couldn't afford to gamble.<sup>45</sup> The biggest recorded game in Dawson comes from Sam Bonnifield and Louis Golden, in which \$200,000 sat in the pot, and Bonnifield won with four aces.<sup>46</sup> It is important to note that cheating was very heavily looked down upon. Compared to the Boom Towns in Alaska, Dawson City served as a paragon of moral superiority, a status that transitioned to the gambling table. Cheating

---

<sup>41</sup> The Chicago Record (1897). *Klondike. The Chicago Record's Book for Gold Seekers*. Pg. 266; Winslow, Kathryn. *Big Pan-Out: The Klondike Story*. Pg. 148; Berton, Pierre. *Klondike: The Last Great Gold Rush: 1896-1899*. Pg. 182.

<sup>42</sup> Archibald, Margaret. 2006. "26." Parks Canada - Canadian Historic Sites: Occasional Papers in Archaeology and History No. 26. <http://parkscanadahistory.com/series/chs/26/chs26-1g.htm>.

<sup>43</sup> Winslow, Kathryn. *Big Pan-Out: The Klondike Story*. Pg. 191.

<sup>44</sup> "An Early Slot Machine." National Parks Service, August 23, 2019. <https://www.nps.gov/klgo/learn/historyculture/slot-machine.htm>.

<sup>45</sup> Winslow, Kathryn. *Big Pan-Out: The Klondike Story*. Pg. 191.

<sup>46</sup> Ibid

is akin to stealing, and stealing within Dawson is a concrete method to being banned from Dawson.<sup>47</sup>

With the rapid fluctuation of money, solid banks needed to be established. Not only did they assist in storing and managing funds earned by prospectors, but they could exchange gold dust earned from panning methods for paper money.<sup>48</sup> Two of the most prominent banks include the Canadian Bank of Commerce and the Bank of British North America.<sup>49</sup> Along with this rapid fluctuation of money came rapid spending. Using the money earned from the Klondike Gold Rush, the United States began building more infrastructure and catching up on the economic developments that they had lost, including the new construction of railroads.<sup>50</sup> The real money came from the rich prospectors, however. Many stores and saloons excessively catered towards these enterprise miners, to the point when the phrase “mining the miners” became popular to demonstrate how industries would mine the miners of their gold.<sup>51</sup> There were other industries, too, such as textiles, fishing, and lumber, but in Dawson City, the only industry that could compete with the rapid gold mining was entertainment.

### Entertainment in Dawson City

Entertainment became a sensation across Dawson City and provided a method for rich prospectors to spend their time and their money. As mentioned, saloons and the gambling within

---

<sup>47</sup> The Chicago Record (1897). *Klondike. The Chicago Record's Book for Gold Seekers*. Chicago: Chicago Records Co. Pg. 273.

<sup>48</sup> Berton, Pierre. *Klondike: The Last Great Gold Rush: 1896-1899*. Pg. 288-289.

<sup>49</sup> “Mining the Miners.” Bank of Canada Museum, June 24, 2016.

<https://www.bankofcanadamuseum.ca/explore/exhibitions/past-exhibitions/temporary-exhibition-mining-the-miners/#:~:text=The%20Bank%20of%20British%20North,the%20Canadian%20Bank%20of%20Commerce>.

<sup>50</sup> Sharer, Rachel. “The Great Klondike Gold Rush.” Norman B. Leventhal Map & Education Center, August 16, 2021. <https://www.leventhalmap.org/articles/the-great-klondike-gold-rush/>.

<sup>51</sup> “Klondike Gold Rush.” Dawson City.ca. Accessed October 25, 2023. <https://dawsoncity.ca/discover-dawson/klondike-gold-rush/>.

them allowed for massive spending within the city. Payments could be made with gold dust, and it was often that a profit could be made by a minor sweeping the floor of a saloon and finding any gold dust that was dropped by a previous patron.<sup>52</sup> It was also very common to see rich prospectors adorned with custom-made jewelry to display their wealth.<sup>53</sup> For rich prospectors, wealth was something they threw away to simply have a good time. Within the downtown area of the city lay a street filled with saloons, dance houses, and operas decorated to mimic the luxury and grandeur of Paris itself.<sup>54</sup> Dance halls provided not only entertainment through the many dancers within these halls but also served as a status symbol for the customers and owners of the establishments.<sup>55</sup> There were also elaborate and decorated opera houses, which would bring musical acts and specialty performances to Dawson.<sup>56</sup> Hotels emerged as well, ensuring that any visitors wishing to spend their time touring and having fun in Dawson had a place to stay, such as the popular Fairview Hotel owned by Belinda Mulrone.<sup>57</sup> The most efficient way to earn money beyond prospecting was through entertainment.

Working in entertainment did not guarantee a comfortable living, however. There is a sizable portion of women who went to entertainment as a source of income, as others either already had income and used it to become wealthier, such as Mulrone, or worked as housewives while their husbands went to mine.<sup>58</sup> There were two different types of women within the entertainment industry: highly paid actresses and elites who similarly lavished in the excessive

---

<sup>52</sup> Berton, Pierre. *Klondike: The Last Great Gold Rush: 1896-1899*. Pg. 84.

<sup>53</sup> Ibid, pg. 363.

<sup>54</sup> Ibid, pg. 358-359.

<sup>55</sup> Ibid, pg. 359.

<sup>56</sup> Winslow, Kathryn. *Big Pan-Out: The Klondike Story*. Pg. 191.

<sup>57</sup> McLaughlin, Les. "Belinda Mulrone." Yukon Nuggets. Accessed October 25, 2023. <https://yukonnuggets.com/stories/belinda-mulrone/>.

<sup>58</sup> Porsild, Charlene L. *Gamblers and Dreamers: Women, Men, and Community in the Klondike*. Vancouver: UBC Press, 1999. Pg. 98.

lifestyle of the enterprise miners and followed in their footsteps of exorbitant spending, and the chorus line dancers and small-time workers who did not earn nearly as much as the elites.<sup>59</sup> These women usually had to double up as hostesses in restaurants and dance hall workers to make a proper living. While they were generally paid better than a majority of male working-class miners, they usually had longer hours and had more expenses to pay off, restricting them from living comfortably.<sup>60</sup> Entertainment is in high demand within Dawson, but supply is dwindling, so ensuring that entertainment can remain is of utmost importance.

One more form of entertainment to note is sports. While the city is new, many are itching to bring sports from home that they are familiar with, including football and hockey. Establishing forms of entertainment that can reduce the waste of gold and money and alleviate the poor living conditions of those in other jobs by reducing the stress of their work could all ensure Dawson City's longevity.

---

<sup>59</sup> Ibid, pg. 113.

<sup>60</sup> Ibid, pg. 114.

# LIFESCAPE

## Health

Stampeders looking to strike gold at Klondike had to face a multitude of health and safety hazards. Klondike boomtowns often dealt with waterborne illnesses like cholera and typhoid. Dawson City, in particular, was prone to typhoid epidemics due to the city's non-existent trash management and sanitation systems. Refuse and garbage were poured into the river, which polluted the water more. To avoid drinking the contaminated water, residents decided to hedge their bets on liquor. Unfortunately, the alcohol available to those in Klondike was so watered down that an observer described it as “whisky-flavored water.” Trapped in liquor bottles, the bacteria that caused typhoid fever bloomed, and among the various tents and cabins propped up in ankle-deep mud, the disease flourished in Dawson. Typhoid fever is most commonly identified by a fever, abdominal pain, and a red, spotty rash known as rose spots. In more serious cases, the infected would enter a “typhoid state,” which involved muttering in delirium and picking at their clothes while experiencing hallucinations.<sup>61</sup> Victims of typhoid most likely caught the illness in the spring and then spent the summer months fighting the illness, either recovering or succumbing to it in the fall.

Respiratory illnesses, spread by sneezing, coughing, sharing glasses, or living with somebody in close quarters for an extended period, also plagued the city.<sup>62</sup> Because boomtowns like Skagway were constantly receiving new visitors, they, too, were susceptible to the various

---

<sup>61</sup> A.; Verghese. “The ‘Typhoid State’ Revisited.” *The American journal of medicine*. Accessed October 29, 2023. <https://pubmed.ncbi.nlm.nih.gov/3898837/>.

<sup>62</sup> Thesis - highet - assets.yukonarchives.ca. Accessed October 29, 2023. <http://assets.yukonarchives.ca/189472.pdf>.

diseases that were present on the trail. Mosquitoes get to be a real problem in the spring and summer as well, as they are the primary transmitters of diseases in the region.<sup>63</sup>

To make matters worse, Klondike residents were often vitamin deficient and experienced scurvy from their diet, which had few fruits and vegetables. Though many residents had scurvy, it was rarely fatal but did worsen their immune systems and make them more susceptible to other diseases that were rampaging the town. Scurvy is characterized by fatigue, swollen gums, a skin rash, anemia, and general weakness.<sup>64</sup> Unlike the treatment of typhoid, which mainly consisted of palliative care because antibiotics had not yet been invented, prospectors were able to combat scurvy with tea made from spruce and cottonwood wood twigs. Scurvy could also be prevented by eating edible berries that were abundant in Klondike, but these berries were often overlooked. Working to promote solutions to these illnesses and raising awareness of their effect in the city may work to mitigate or prevent future outbreaks.

Weather-related injuries were also common in Klondike. In the winter, residents dealt with hypothermia, but spring was known among indigenous people and settlers as by far the most dangerous season. The melting of snow created the perfect conditions for avalanches, and as the ground thawed and snow melted, run-off water found its way into the soil. This means that the once structurally sound mines, which had the structural support of frozen, solid dirt walls, now had to hold up the weight of themselves and the water-saturated soil. Many mines collapsed, burying miners alive.

---

<sup>63</sup> “Mosquito,” Hinterland Who’s Who, Canadian Wildlife Federation, accessed October 20, 2023, <https://www.hww.ca/en/wildlife/invertebrates/mosquito.html>.

<sup>64</sup> “Vitamin C.” Mayo Clinic, August 10, 2023.

<https://www.mayoclinic.org/drugs-supplements-vitamin-c/art-20363932#:~:text=Severe%20vitamin%20C%20deficiency%20can,naturally%20occurring%20antioxidants%20in%20food.>

Finally, residents of boomtowns had to contend with the trauma of physical violence that infested boomtowns. For instance, in Skagway, up to sixty percent of the incarcerated population up until 1903 had committed violent offenses, and twenty percent of all deaths were caused by trauma related to violence.<sup>65</sup> The treatment for injuries related to physical trauma often involved attempts to stop the bleeding and, in some cases, morphine to ease the pain.

### Law Enforcement

Police in boomtowns were scarce as they were expensive, and governments were unwilling to spend money on a town they weren't sure would expand. As a result, law enforcement was present but was often stretched thin, upholding multiple roles and duties. In Klondike, the Canadian NWMP (North West Mounted Police), also known as "mounties," led the charge in preventing crime by making sure travelers were well prepared. Sam Steele, an officer in the Canadian NWMP, created the rule that stampeders would need a year's worth of goods to support themselves to access and settle in Dawson City. While this requirement may seem extreme, it was incredibly necessary for newcomers to survive the brutal Klondike winters. The police also took on civil service roles by working with community members to improve the city's sanitation systems, which mitigated the numerous typhoid outbreaks.

The Canadian Mounties also prevented death by policing the river and inspecting boats. After travelers finished the Chilkoot or White Pass trail, they would need to buy or build a boat that could carry them down the Yukon River for 550 miles. Many travelers were not experienced

---

<sup>65</sup> "Rushing to the Grave (U.S. National Park Service)." National Parks Service. Accessed October 29, 2023. <https://www.nps.gov/articles/klgo-death.htm#:~:text=Acts%20of%20violence%20also%20occurred,journey%20while%20in%20Dawson%20City>.

and had little to no knowledge of boat-building, so as a result, they would die along the way to Dawson City when their improperly made boat sank. The NWMP then created a system where they would inspect and register each boat before it was permitted to sail down the river. The police force also established various checkpoints along the river that prevented stampeders from crossing the rapids in their flimsy boats. As a result, the number of fatalities decreased despite the river's obstacles.

### Crime

Due to the overworked police force, the conditions were perfect for crime. While physical violence was frequent and fighting broke out daily due to scarce resources and a desperate population, the most common crimes were simple cons and thefts. For instance, notorious con man Jefferson Randolph Smith, the second, or “Soapy” Smith, had skipped town several times before coming to Klondike to set up another scheme.<sup>66</sup> “Soapy” and his followers created a mafia-like presence within the town of Skagway, making their name as one of the town's most notorious swindlers. Smiths Bar, known as Jeff Smith's Parlor, was seen as the “real” city hall despite the presence of an official one. His arrival in the town opened the doors for gang and vigilante action.

Punishment for crime in Klondike largely depended on who you were with; most sentences involved jail time, but there were cases of whippings, and if the crime was murder, hangings.<sup>67</sup> It should be noted that hangings were rare, and from 1899 to 1932, only ten hangings took place in Dawson City and thirteen in the Yukon. The punishment for a crime was also issued

---

<sup>66</sup> Legends of America. Accessed October 29, 2023. <https://www.legendsofamerica.com/we-soapysmith/>.

<sup>67</sup> “Ton of Goods.” National Parks Service. Accessed October 29, 2023. <https://www.nps.gov/klgo/learn/historyculture/tonofgoods.htm>.



without an account for the alleged perpetrator's age, as Jim Nantuck, a First Nation boy in his teens, was among those hanged for murder.<sup>68</sup>



---

<sup>68</sup> Klondike Gold Rush capital punishment the convicted at former Fort Herchmer. Accessed October 29, 2023. [https://www.alaskaanthropology.org/wp-content/uploads/2017/08/akanth-articles\\_384\\_v10\\_n12\\_Mooney-Hare.pdf](https://www.alaskaanthropology.org/wp-content/uploads/2017/08/akanth-articles_384_v10_n12_Mooney-Hare.pdf).

# JOURNEY TO THE KLONDIKE

## Weather and Seasons

Many began their journey to the Klondike in the upper northwest regions of the United States, Seattle becoming a popular starting point.<sup>69</sup> The journey could take about a year from these cities due to harsh conditions and difficult terrain.<sup>70</sup> As such, one would likely begin over the summer to depart and settle down as easily as possible, but that also meant that the weather during travel would be intensely difficult. The trek was mostly on foot, with a few pack animals and sled dogs to help along the way. Winter temperatures could be expected to be about negative twenty degrees Fahrenheit but could get as low or even lower than negative fifty degrees Fahrenheit. Because of the remote nature of the journey, shelter warmer than tents couldn't be found.<sup>71</sup> Depending on how late into the boom one embarked on their journey, wood, native game, and forageable plants too may have been scarce, as biodiversity disappeared later into the boom due to previous travelers overconsuming natural resources from the trails. Along with the depletion of natural resources, traveling also led to pollution, trash, and waste, becoming a problem for future settlers.<sup>72</sup>

---

<sup>69</sup> "Gardening in Skagway (U.S. National Park Service)." National Parks Service. Accessed January 5, 2024. <https://www.nps.gov/articles/klgo-skagway-gardening.htm>.

<sup>70</sup> "Klondike Gold Rush," Historynet, accessed October 20, 2023, <https://www.historynet.com/klondike-gold-rush/#:~:text=Because%20of%20the%20harsh%20terrain,a%20long%20and%20arduous%20journey..>

<sup>71</sup> "The Klondike Gold Rush," Digital Collections, University of Washington Library, February 4, 2002, <https://content.lib.washington.edu/extras/goldrush.html>.

<sup>72</sup> "Environmental Consequences of the Gold Rush," National Park Service, U.S. Department of the Interior, last modified May 1, 2018, <https://www.nps.gov/klgo/learn/historyculture/environmental-impacts.htm>.

## Routes to Dawson City

There were two main routes to Dawson City: The White Pass Trail coming to Skagway and the Chilkoot Trail coming to Dyea. Both were treacherous. The White Pass Trail was known for having outlaws who would scam travelers at any given opportunity, but the Chilkoot Trail was a lot steeper, so options were very limited. Malnutrition and frostbite were common, and conditions were bleak. Due to the difficulty of travel, horses would often die on the road, and many travelers resorted to eating these horses. The White Pass Trail became known as the Dead Horse Trail due to this.<sup>73</sup> The terrain was frozen, cold, and treacherous, with frozen rivers and mountains, and even the minimum of one year's worth of supplies Canadian Authorities required each group to have even to attempt the journey was often inadequate.<sup>74</sup>

There was also a third route: the water route, or the St. Michaels route, which was the easiest, safest, and thus, the most expensive.<sup>75</sup> Additionally, due to this path requiring the water to be utilized, it could only be taken from June to September, as the waters leading to the region were frozen for the rest of the year.<sup>76</sup> Many previously wealthy prospectors utilized this path to reach Dawson City, but it simply was not feasible for the majority of travelers. Regardless, no path was easy and required a great deal of determination.

---

<sup>73</sup> University of Washington, "The Klondike Gold Rush."

<sup>74</sup> National Park Service, "Environmental Consequences."

<sup>75</sup> Murray Lundberg, "Stampede Routes to the Klondike Gold," ExploreNorth, accessed October 20, 2023, [https://www.explorenorth.com/klondike/klondike-stampede\\_routes.html](https://www.explorenorth.com/klondike/klondike-stampede_routes.html).

<sup>76</sup> "Trails to the Klondike." National Postal Museum. Accessed January 5, 2024.

<https://postalmuseum.si.edu/exhibition/as-precious-as-gold-stories-from-the-gold-rush-the-trails/trails-to-the-klondike>.

# SCIENCE, TECHNOLOGY, AND COMMUNICATION

## Building Infrastructure

At the time of the Klondike Gold Rush, Dawson City's infrastructure lacked the amenities that were prevalent in cities further south. The city relied on two springs to gather clean water since the Yukon River had been polluted from waste being dumped into the river.<sup>77</sup> Contaminated water is incredibly unsafe and festers diseases, such as typhoid.<sup>78</sup> The only way to access (somewhat) safe water from the river would be to boil it, although the human waste in the water had a dramatic stench. Sewage lines were nonexistent, causing waste to build up in the streets and churn into muddy roads during the warmer seasons. Lining the streets were houses, saloons, brothels, and shops made of wood with little access to electricity.<sup>79</sup> Dawson City residents used oil lamps to light up the buildings at night and heated themselves with wood-burning stoves. There was also no established fire brigade in Dawson City in 1896, so fires caused by these heat and light sources were often a considerable concern to citizens.<sup>80</sup> Dawson City had a police presence in the region to enforce laws, yet there were no established schools or places of worship in the town for its first few months.

---

<sup>77</sup> “Big Pan-out : The Klondike Story. -- : Winslow, Kathryn : Free Download, Borrow, and Streaming.” Internet Archive, January 1, 1970. <https://archive.org/details/bigpanoutklondik0000wins>.

<sup>78</sup> (Hight 2008, 123)

<sup>79</sup> Ibid.

<sup>80</sup> Ibid.

## Technology of the Time

There were many prevalent means of transportation technology during the Klondike Gold Rush. An established way of transportation for many people was through the use of a horse-drawn wagon or carriage. During the Klondike Gold Rush, North America was at the height of its “carriage era,” which helped navigate the unpaved roads found in most of the continent.<sup>81</sup> In addition to the carriage, the electric streetcar (or trolley) was first introduced to the world in Cleveland, Ohio, in 1884, offering a new way for people to move via rail.<sup>82</sup> On a much larger scale, the railroad, a means of transportation less common than the carriage, has also begun to expand the scope of its usefulness and availability. In 1869, the Transcontinental Railroad was finished along the latitude of the United States, offering a new, faster way for people to travel along the breadth of the American continent.<sup>83</sup> In Canada, the Canadian Pacific Railway, spanning from east to west, was completed 16 years after the Transcontinental Railroad, providing Canadians interested in the Klondike Gold Rush a way to reach the west coast of Canada (but not directly to Dawson City).<sup>84</sup> Water transportation had also seen significant overhauls due to advancements in steam engine technology. While steamboats existed since the late 1700s, the steam engine turbine was first placed in the Turbinia in 1894, making it the fastest boat in the

---

<sup>81</sup> Introduction: Transportation in America and the carriage age. Accessed October 18, 2023.

<https://parkcityhistory.org/wp-content/uploads/2012/04/Teacher-Background-Information.pdf>.

<sup>82</sup> “Milestones in U.S. Public Transportation History.” APTA: Milestones in U.S. Public Transportation History. Accessed October 17, 2023.

<https://web.archive.org/web/20090303212350/http://apta.com/research/stats/history/mileston.cfm>.

<sup>83</sup> “Transcontinental Railroad - Construction, Competition & Impact.” History.com. Accessed October 17, 2023.

<https://www.history.com/topics/inventions/transcontinental-railroad>.

<sup>84</sup> “Canadian Pacific Railway Is Completed.” Your Museum. Your Stories. Accessed October 17, 2023.

<https://www.historymuseum.ca/blog/canadian-pacific-railway-is-completed/#:~:text=On%20November%207%2C%201885%2C%20the,of%20the%20Canadian%20Pacific%20Railway>.

world.<sup>85</sup> In regards to Dawson City, there was currently limited port access and no direct railroad access, although steamboats seem to be a very promising method of transportation into and out of the city. If members of the committee wish to make Dawson City self-sustainable, ensuring effective transportation, especially through steamboat, is imperative.

The transportation sector had not been the only sector with innovations in technology, as a new form of entertainment technology was being researched and developed called “film.” Pioneered by the Lumière brothers, their invention of the “cinématographe” showed the world a new form of delivering information to large audiences with the first public showcase of their creation in 1895.<sup>86</sup> With public demand at an ever-increasing rate, the future of film usage appears to rival the widespread use of the telegraph and the appeal of the telephone and is a draw for many prospectors to go to Dawson City, as the entertainment industry is a thriving element of the city.

### **Journalism, Press, and How Information Spreads**

Significant improvements in communication technology have made information transmissions easier than ever before, leading to a massive interest in journalism within Dawson City. In 1844, the first message called a telegram, was sent over the telegraph.<sup>87</sup> Since then, the telegraph network has expanded across the Atlantic Ocean to Europe and spread across the

---

<sup>85</sup> “Turbinia.” What’s On | Discovery Museum. Accessed October 17, 2023.

<https://discoverymuseum.org.uk/whats-on/turbinia#:~:text=In%201894%20he%20built%20the,central%20hall%20at%20Discovery%20Museum.>

<sup>86</sup> “The World of Science - Newspapers.ComTM.” Newspapers.com, October 19, 1895.

[https://www.newspapers.com/article/democrat-and-chronicle-the-world-of-scie/104163798/.](https://www.newspapers.com/article/democrat-and-chronicle-the-world-of-scie/104163798/)

<sup>87</sup> Transportation Revolution of the 19th century. Accessed October 18, 2023.

[https://www.somersschools.org/cms/lib/NY01913963/Centricity/Domain/1252/American%20History%20-%20transportation%20revolution%20of%20the%2019th%20century.pdf.](https://www.somersschools.org/cms/lib/NY01913963/Centricity/Domain/1252/American%20History%20-%20transportation%20revolution%20of%20the%2019th%20century.pdf)

country in over 23,000 miles of telegraph lines.<sup>88</sup> Furthermore, in 1876, the telephone was created, allowing people to speak to one another across large distances. Over two decades, the telephone lines have gone from the inter-room lines of 1876 to inter-city and trans-city lines, with lines reaching from cities such as New York to Chicago.<sup>89</sup> Within Dawson City, the telegraph is widely used, but the telephone is difficult to access, as due to the scarcity of the technology, phone calls are only held by reserving a telephone booth.<sup>90</sup>

While the telegraph was present, the most prolific form of communication came from the news. Klondikers were clawing at the newspaper industry for access to information about the outside world. This market of desperate customers has led to a race between publications to see who can be the first to dominate and own the first printing press in the Yukon.<sup>91</sup> There was a large number of journalists living in Dawson to document the lives of prospectors, but there was a shortage of paper and a complex mail system that also caused significant delays in getting information out to the world beyond Klondike.<sup>92</sup> To start, any mail from America intended for Dawson City would first make its way to Juneau in southeastern Alaska. From Juneau, it would then travel through Dawson and proceed downstream along the Yukon River until reaching Circle City. Subsequently, the US Postal Service would manage the distribution of this mail, routing it back up to Dawson.

---

<sup>88</sup> “Telegraph History: Telecom-Milestones.” telecom. Accessed October 17, 2023.

<https://www.telecom-milestones.com/telegraph-historyblank#:~:text=From%201846%20private%20companies%20begin,Atlantic%20telegraph%20line%20was%20completed.>

<sup>89</sup> “Contents.” chicagology. Accessed October 17, 2023. <https://chicagology.com/goldenage/1892telephone/>.

<sup>90</sup> “A Brief History of the Office Phone Booth.” My office pod, October 10, 2023.

<https://myofficepod.co.uk/a-brief-history-of-the-office-phone-booth/>.

<sup>91</sup> Klondike. The Chicago Record’s book for Gold Seekers. Accessed October 29, 2023.

<https://archive.org/details/klondikechicagor00chic>.

<sup>92</sup> “Klondike : The Last Great Gold Rush, 1896-1899 : Berton, Pierre, 1920-2004 : Free Download, Borrow, and Streaming.” Internet Archive, January 1, 1970.

[https://archive.org/details/klondikelastgrea0000bert\\_m1g1/page/n9/mode/2up](https://archive.org/details/klondikelastgrea0000bert_m1g1/page/n9/mode/2up).

Aside from written information, words of scandal, conflicts, and shortages were passed on like they were in any small town. Word of mouth was a powerful tool to be weaponized by the right people, and a strong community among women in the city allowed for any spoken information to travel rather quickly. It was common for journalists to catch wind of this and encourage the process as a means to create demand for their profession. Ensuring the continued development of communication within Dawson City, through newspapers, telegraph, and more, can work to ensure the longevity of the town.

### Mining Process

Due to the differences in how the gold was dispersed in the Klondike, several methods of extracting the gold were used. The least technologically advanced but simplest method to extract gold was the panning method. When panning for gold, prospectors would scoop minerals up from creek beds in a handheld pan, agitate the rocks with water, and wash out rocks that rise to the top in hopes of extracting gold from the bottom of the pan.<sup>93</sup> While this method was simple and cost-effective, it was not efficient. Another method of gold extraction was by rocker box. A rocker box works similarly to the panning method but on a larger scale. A prospector would place dirt from a creekbed in the top hopper, pour water on the soil in the hopper, and then rock the Rockbox back and forth quickly to aggregate the soil and filter the gold onto the riffles.<sup>94</sup> It gives the impression of quickly rocking a baby

<sup>93</sup> “How to Pan for Gold - Beginner Tips and Techniq  
Equipment Detectors Snake Protection. Accessed Jar  
[https://www.goldrushtradingpost.com/how\\_to\\_pan\\_f](https://www.goldrushtradingpost.com/how_to_pan_f)

<sup>94</sup> How to mine and prospect for Placer Gold. Access  
<https://web.archive.org/web/20120404213310/http://17h10>.

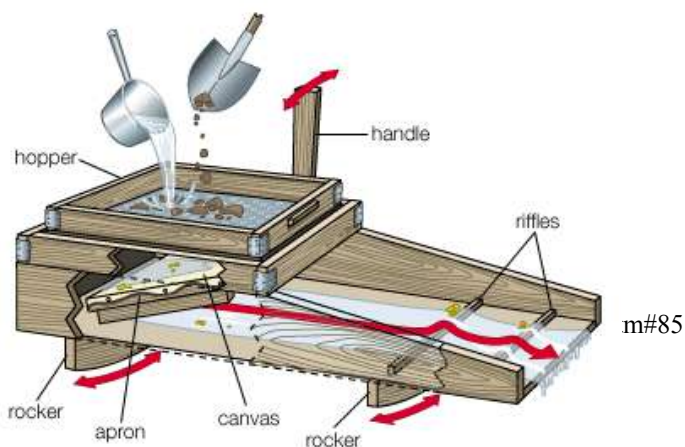



within a crib. Rocker box extraction was more efficient than panning, but there were other extraction methods. Underground mining was commonly used, in which prospectors would light a fire on the area they wanted to mine and let the fire burn overnight. The fire would cause the ground to thaw from the permafrost, allowing for easier extraction.<sup>95</sup> Afterward, prospectors would dig up the region in hopes of finding gold. If they failed, they would continue the process until successful, resulting in deep mining shafts across the region. Hydraulic mining was also used, in which prospectors would deliver water to a site they believe contains gold, then with a difficult-to-obtain high-pressure hose, wash away the sides of a cliff in hopes that within the boulders and gravel blasted off the cliff, ounces of gold would appear.<sup>96</sup> This method was found to be highly effective and easy for prospectors to use since it was able to move a large amount of dirt and gravel with hardly any effort.<sup>97</sup> Prospectors differed in their economic ability to utilize these gold extraction methods. Many could not afford the equipment needed for underground mining or hydraulic mining, so they resorted to the less effective methods of panning and rocker boxes. There is inequality regarding the ability to find gold, as those already at an advantage can take much more than newer and poorer prospectors. This inequality between rich and poor prospectors may be a divide the committee will have to address.

---

<sup>95</sup> Information sharing during the Klondike Gold Rush - Simon Fraser University. Accessed October 18, 2023. <https://www.sfu.ca/~allen/klondike.pdf>.

<sup>96</sup> “Hydraulic Mining Techniques, California, 1870s.” Hydraulic mining techniques, California, 1870s | U.S. Geological Survey. Accessed October 18, 2023. <https://www.usgs.gov/media/images/hydraulic-mining-techniques-california-1870s#:~:text=Hydraulic%20mining%20was%20a%20variation,the%20miners%2C%20ounces%20of%20gold>.

<sup>97</sup> Hydraulic gold mining - history and current use. Accessed October 18, 2023. <https://mineralexpert.org/article/hydraulic-mining-placer-gold-monitor#:~:text=Hydraulic%20mining%20is%20easy%20and,and%20Alaska%20gold%20rush%20events>.

# SUSTAINABILITY AND THE SUPPLY CHAIN

## Rations and the Supply Chain

As Dawson City could not sustain itself during the Gold Rush, many travelers brought rations and other important equipment with them to ensure access to food and other necessities. The Canadian Government decreed that someone who ventured to the Klondike must bring at least three (3) pounds of food per day for a year, and those who did not bring this food were turned away to stop the unruly or unprepared from entering.

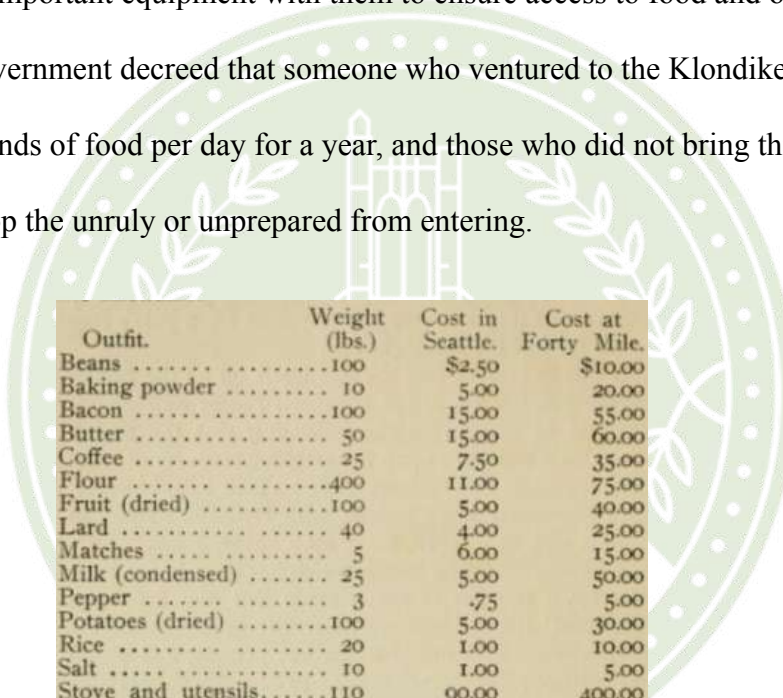

Outfit.	Weight (lbs.)	Cost in Seattle.	Cost at Forty Mile.
Beans .....	100	\$2.50	\$10.00
Baking powder .....	10	5.00	20.00
Bacon .....	100	15.00	55.00
Butter .....	50	15.00	60.00
Coffee .....	25	7.50	35.00
Flour .....	400	11.00	75.00
Fruit (dried) .....	100	5.00	40.00
Lard .....	40	4.00	25.00
Matches .....	5	6.00	15.00
Milk (condensed) .....	25	5.00	50.00
Pepper .....	3	.75	5.00
Potatoes (dried) .....	100	5.00	30.00
Rice .....	20	1.00	10.00
Salt .....	10	1.00	5.00
Stove and utensils.....	110	90.00	400.00
Pick, shovel, ax, hatchet, etc. ....	20	15.00	125.00
Tea .....	25	8.00	40.00
Totals .....	1,143	\$196.75	\$1,000.00

*Recommended Klondike rations list for 6 months*

Although the list above was recommended for people journeying to the Klondike, most had less than the recommended amounts.<sup>98</sup> Supplies were prone to being lost or damaged during the journey, complicating the supply chain further. Gold prospectors could carry their supplies up by themselves or pay companies to carry them. If supplies were bought in the United States, prospectors had to pay the Canadian Mounted Police to allow transit of the goods. prospectors utilized what transportation they could, such as boats, carriages, or horses, to assist in their supply movement, but many still had to walk the journey.<sup>99</sup>



When rations ran out, the supply chain brought food and supplies regularly to Dawson City. The supply chain spanned the Yukon River down to coastal cities like Seattle or San Francisco. Unfortunately, since the supply chain was so massive and transported by boat, it was slow to deliver resources, especially in the winter months.<sup>100</sup> The supply boat was unreliable, with too few supplies and with the possibility of being sunk, resulting in a starvation winter, in which a winter of very little food, leading to many within Dawson City starving to death.<sup>101</sup> The American government has intervened if conditions are especially dire, such as when they imported 600 reindeer straight from Norway to be ranches.<sup>102</sup>

<sup>98</sup> Chicago Record. 1986. Klondike: The Chicago Record's Book for Gold Seekers : Profusely Illustrated. N.p.: Desmond Pub.

<sup>99</sup> Ton of Goods, National Park Service ("Ton of Goods - Klondike Gold Rush National Historical Park (U.S" 2018)

<sup>100</sup> ("Environmental Consequences of the Gold Rush - Klondike Gold Rush National Historical Park (U.S" 2018)

<sup>101</sup> Robinson, Sally. 2010. "Humble Dreams: An Historical Perspective on Yukon Agriculture Since 1846."

<sup>102</sup> McLaughlin, Les. n.d. "Facts, Photos and News Radio." Yukon Nuggets. Accessed October 21, 2023. <https://yukonnuggets.com/stories/the-starvation-winter/>.

The United States was not reliable, but if pressured, they could be convinced to provide further support for American prospectors.

As a whole, the committee should address the supply chain at some point. Another starvation winter would be devastating to the longevity of Dawson City. If the city is to remain growing and active, ensuring citizens have decent access to food is imperative. The committee should focus on developing the infrastructure of the supply chain for easier transit, limiting theft on the trails, and working with local authorities to ensure the continued protection of goods.<sup>103</sup> That way, the committee can ensure the continued success of Dawson City, and prevent a total hunger collapse.

### Transportation

Travel around Dawson City for work or resource gathering originally occurred by horseback, but horses would die very frequently, however, as it was typical for them to be worked to death, freeze, or starve.<sup>104</sup> Rather, dogsled transport was utilized. When the town was first established, dogs were used by the residents to help transport wood, resources, and mining supplies. Dog sleds were a crucial part of Dawson City's connection with the outside world, offering a way to deliver mail and other resources in and around the Yukon.<sup>105</sup>

Dawson City's connection to the outside world was primarily attributed to the dogs's



<sup>103</sup> "Ton of Goods." National Parks Service. Accessed January 2014. <https://www.nps.gov/klgo/learn/historyculture/tonofgoods.htm>

<sup>104</sup> "History of the White Pass Trail - Klondike Gold Rush National Historical Park." National Parks Service. <https://www.nps.gov/klgo/learn/historyculture/white-pass-trail.htm>

<sup>105</sup> Auston, Julie-Anne. n.d. *The Origins of Dogsled Mail in the Klondike*. <https://www.historymuseum.ca/cmhc/exhibitions/cpm/smail/sn>

reliability and capacity to handle subzero temperatures.<sup>106</sup> However, sled dogs don't come without issues. They were only efficient during the winter, and during the off seasons, they were often taken care of by specific dogsled trainers. Additionally, they eat significantly more than horses. It is said that sled dogs can easily eat up to 10,000 calories a day, with a diet consisting of salmon and chunks of meat.<sup>107</sup> Sled dogs, known for their high energy and work ethic, needed to consume large amounts of food to sustain themselves over their frigid journeys, but can be used for more purposes than horses, such as hunting and foraging.<sup>108</sup> Dogsled travel does seem to be a more versatile form of transport than horses but also costs more to manage. A focus of the committee could be to expand the usage of dogsleds, considering their existing effectiveness.

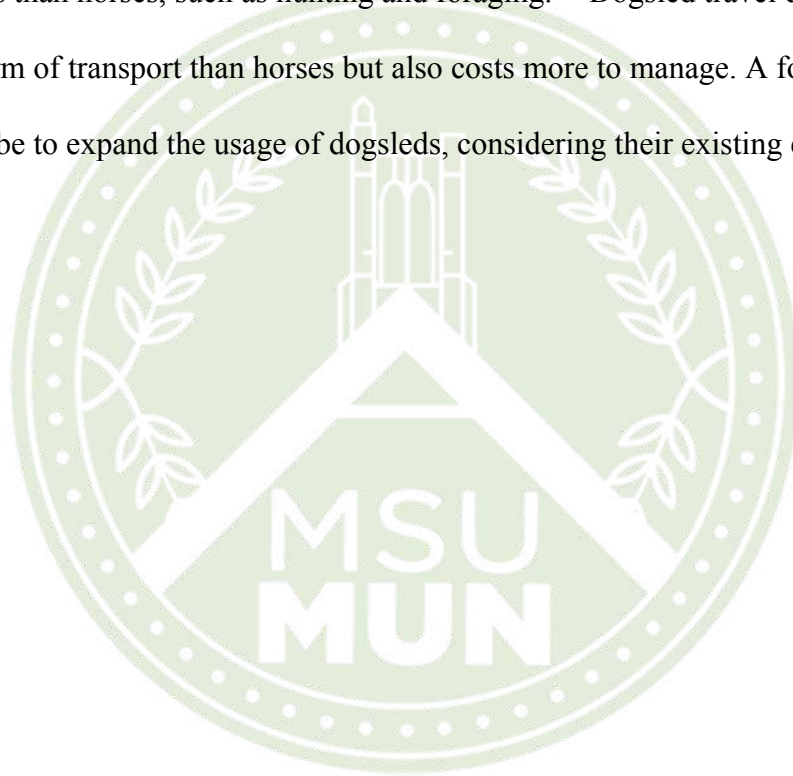

---

<sup>106</sup> “History of Dog Sledding.” Hurtigruten Norwegian Coastal Express. Accessed October 29, 2023. <https://www.hurtigruten.com/destinations/norway/inspiration/attractions/history-of-dog-sledding/>.

<sup>107</sup> Hetta Huskies. n.d. “Nutrition.” Hetta Huskies. Accessed October 21, 2023. <https://www.hettahuskies.com/en/our-farm-dogs/our-dogs/nutrition>.

<sup>108</sup> “Iditarod Sled Dog Nutrition: Q&A with an Iditarod Veterinarian.” Pet Food Institute, April 28, 2020. <https://www.petfoodinstitute.org/blog/iditarod-sled-dog-nutrition-qa-with-an-iditarod-veterinarian/>.

# SOCIETAL, CULTURAL, AND POLITICAL STATUSES

## Indigenous Peoples

### Social Class

The treatment experienced by the indigenous peoples in the Klondike region was infamously terrible. The influence of the Presbyterian church and their missionaries coming to Klondike led to the popularization of a negative outlook on the cultural practices of these groups.<sup>109</sup> It also led to an influx of indigenous peoples taking up membership in the Presbyterian church, dissolving previous attempts made by indigenous groups to maintain their practices.<sup>110</sup> Many indigenous groups still attempted to preserve their culture either by moving their tribes away from Dawson City or by actively resisting occupation from colonizing forces from Russia, Canada, and America. This proved difficult with the continued theft of land and forced removal from their homes, as well as the ignorance many residents of Dawson City have regarding the indigenous. Addressing the continued mistreatment and misrecognition of indigenous groups is imperative for Dawson City to continue as a legitimate settlement.

### The Han

The Han Athabascan group are the first documented inhabitants of the Yukon region and were the first indigenous group to trade & barter with incoming foreigners. The region they lived

---

<sup>109</sup> “Klondike Gold Rush NHP: Legacy of the Gold Rush: An Administrative History of Klondike Gold Rush National Historical Park (Chapter 1).” National Parks Service. Accessed October 29, 2023. [https://www.nps.gov/parkhistory/online\\_books/klgo/adhi/chap1.htm#:~:text=Most%20anthropologists%20consider%20that%20the,division%20of%20the%20Tlingit%20Indians](https://www.nps.gov/parkhistory/online_books/klgo/adhi/chap1.htm#:~:text=Most%20anthropologists%20consider%20that%20the,division%20of%20the%20Tlingit%20Indians).

<sup>110</sup> “Staking Claims: The Gold Rush in Nineteenth-Century America.” Who Was Marginalized | DPLA. Accessed October 29, 2023. <https://dp.la/exhibitions/gold-rush/who-was-marginalized/native-americans>.

in, the easternmost part of the Yukon River, became integral hubs essential to the Klondike gold mining industry, at the expense of their cultural practices being infringed upon by the sudden overwhelming foreign influence of both American and Canadian prospectors from the east.

Later in history, the Han group would be granted a reserve three miles down the river from Dawson City by the Canadian government. This would come to be called the village of Moosehide, and it was created to preserve the Han linguistic group in the Dawson area, known as the Tr'ondek Hwech'in.

### **The Tagish**

The Tagish people gained their stake in Klondike history by being the ones to make the gold discovery that was used to usher in the gold rush.<sup>111</sup> This ethnolinguistic group lived mostly at Marsh, Carcross, and Tagish Lake. They had the most amicable relationship with the Tlingit group and frequently intermarried, causing their cultural practices to be deeply intertwined with one another. Despite this relationship, the group still made efforts to distinguish their language and culture from that of their allies to be preserved for future generations.

### **The Tlingit**

The coastal group of the Tlingits is renowned for having the most kinship with the land where the Klondike Gold Rush takes place. Their first contact with Europeans came in 1741 when they were approached by Russian explorers.<sup>112</sup> Aleksey Chirikov was the Russian explorer who sent teams to make contact with the Tlingit people. After two teams went missing, contact

---

<sup>111</sup> "Tagish." YNLC•Tagish. Accessed October 29, 2023.

<https://web.archive.org/web/20070710053256/http://www.yukoncollege.yk.ca/ynlc/languages/tg/tg.html>.

<sup>112</sup> "History." The Tlingit People. Accessed October 29, 2023. <https://thetlingitpeople.weebly.com/history.html>.

was limited until the Russians began colonizing indigenous groups to the north of the Yukon. In 1802, more aggressive Russian efforts occurred to try to “subdue” the Tlingit people, but they were met with vehement opposition.

Their resistance to occupation was largely successful until 1836-1840, when diseases such as smallpox, influenza, and tuberculosis decimated an estimated half of the Tlingit people.

<sup>113</sup> This coincided with the Americans coming to their lands due to the 1867 Treaty Purchase of Alaska. The Tlingit people continued to resist occupation attempts from both Russian and American forces, but after an attack and thereby destruction of the Tlingit village Kake in the 1860s and Angoon in 1882 by the American military, foreign occupancy of their region was firmly established.<sup>114</sup>

### **The Chilkoot**

The Chilkoot native group was known for resisting outside influence and sufficiently preventing outsiders from entering. Their mission was to “prevent[ed] any white man from going through the pass.”<sup>115</sup> A fort was built that would have lessened their monopoly on trade between the coastal and inland groups of their tribe in 1848. In 1852, it was pillaged and burnt to the ground with no remains left behind. There was one mountain pass their domination of the region did not encompass, and later missionaries and prospectors would exploit this pass to subjugate this group.

---

<sup>113</sup> “Tlingit.” Countries and Their Cultures. Accessed October 29, 2023. <https://www.everyculture.com/multi/Sr-Z/Tlingit.html#b>.

<sup>114</sup> Ibid.

<sup>115</sup> “Yukon Indians and the Gold Rush.” Who Discovered the Klondike Gold? Accessed October 29, 2023. <https://www.canadianmysteries.ca/sites/klondike/context/firstnationshistory/4381en.html>.



## The Tutchone

The Tutchone group was known for their economic prowess in the fur trade once relations with Europeans began to increase. They were known to be skilled hunters with “a wealth of furs and tanned and untanned skins to trade.” They were also frequently invaded by the Tlingit group as a part of trade route modifications meant to prevent these relationships.<sup>116</sup>

## Women in Boomtowns and Dawson City

### Social Class

It is estimated that for every dozen men in Klondike, there would only be one woman.<sup>117</sup> One might think that this disproportionate population would lead to the enforcement of the typical patriarchal gender roles, but the unique circumstances of the gold rush allowed women to capitalize on the looser structures of morality and societal norms and fulfill roles frequently thought of as designated for men.<sup>118</sup> The women of Klondike had a much wider variety of directions to take their lives compared to back home. Women in boomtowns saw more economic opportunities, a higher divorce rate, and a wide variety of occupations to choose from both inside and outside the home.<sup>119</sup>

---

<sup>116</sup> “Klondike Gold Rush NHP: Legacy of the Gold Rush: An Administrative History of Klondike Gold Rush National Historical Park (Chapter 1).” National Parks Service. Accessed October 29, 2023. [https://www.nps.gov/parkhistory/online\\_books/klgo/adhi/chap1.htm](https://www.nps.gov/parkhistory/online_books/klgo/adhi/chap1.htm).

<sup>117</sup> “Staking Claims: The Gold Rush in Nineteenth-Century America.” Who Was Marginalized | DPLA. Accessed October 29, 2023. <https://dp.la/exhibitions/gold-rush/who-was-marginalized/women>.

<sup>118</sup> “Women of the Gold Rush.” National Parks Service. Accessed October 29, 2023. <https://www.nps.gov/klgo/learn/historyculture/women.htm>.

<sup>119</sup> Yes, women participated in the gold rush - JSTOR DAILY. Accessed October 29, 2023. <https://daily.jstor.org/yes-women-participated-in-the-gold-rush/>.

## Occupations

Women were not restrained in terms of what career they could go into. Many women took advantage of the Klondike Gold Rush as a means of seeking out adventure and excitement. The most commonly listed options were the following: “miners, business women [sic], journalists, shopkeepers, cooks, nuns, entertainers, teachers, physicians and hotel proprietors.” Outside of those, many of the women in Dawson came to just see what Klondike Fever was all about and possibly invest in certain prospectors to increase their own wealth.

## Gender Roles in Klondike

The lessened presence of moral culture in boomtowns does not necessarily mean that gender roles were eliminated. Americans, Canadians, and Russians alike all carried with them the societal expectations of women, just like the supplies they carried. The exception would be the indigenous groups of the region, and although not all of them have an explicit history of gender roles in their cultures, it is evident that most of them are not as patriarchal as the European approach.

The difference between the East, where women were expected to take joy in fulfilling the duties expected of them, and the Western frontier’s philosophy was that homemaking skills (cooking, laundry, cleaning, and sewing) were viewed as an economic commodity. Marriage itself was considered an investment and economic prospect due to these homemaking skills and the idea of paying a woman to be married to her and gain access to these skills. The idea was that marriage would increase your likelihood of survival against the harsh winter conditions.

## Children and Family

Despite the harsh conditions of the Yukon region, the domestic population of Dawson City increased quickly. For the most part, women engaged in the gold rush alongside their prospector husbands and were equally excited by the “get rich quick” idea. As of 1898, 400 Klondiker children were also participating in the gold rush just as eagerly, albeit less willingly than their mothers and fathers.<sup>120</sup> The conditions of the Yukon did not deter many prospectors from creating their own families in Dawson and increasing the already prevalent strain on local resources.

The benefit of having an increasing population made up largely of families such as the aforementioned children was that there was also an increase in demand for systems such as sanitation and public health, which, if this demand is met, could drastically increase the quality of life for the citizens of Dawson. This also creates the demand for more permanent living spaces to sustain the families being formed.

## Religion

The major religions of Dawson were all denominations of Christianity.<sup>121</sup> The Roman Catholic church overwhelmingly had the most members, followed by the Presbyterian, Anglican, and Lutheran congregations. The Presbyterian church was known for making the most efforts to send missionaries to Dawson itself and to the local indigenous groups in an attempt to convert them. As a part of this effort to establish its dominance over the town, it lent monetary help to

---

<sup>120</sup> Porsild, Charlene. Klondike Family Life, September 29, 2005. file:///Users/christianallmand/Downloads/ebarsky,+1509-6226-1-CE.pdf.

<sup>121</sup> By F. A. Peake\* - JSTOR. Accessed October 29, 2023. <https://www.jstor.org/stable/pdf/43748488.pdf>.

fund public facilities that the town's families demanded. They could not build them from the ground up, but if one is looking for the money to invest in these sectors, the Presbyterian church would be a good place to start.<sup>122</sup>

“About Robert W. Service | Academy of American Poets.” n.d. Poets.org. Accessed November 8, 2023. <https://poets.org/poet/robert-w-service>.



---

<sup>122</sup> Ibid.

## REFERENCES

“A Brief History of the Office Phone Booth.” My office pod, October 10, 2023.

<https://myofficepod.co.uk/a-brief-history-of-the-office-phone-booth/>.

“Annie Hall Strong (U.S. National Park Service).” National Parks Service. Accessed November 1, 2023. <https://www.nps.gov/articles/000/annie-hall-strong.htm>.

A; Vergheze. “The ‘Typhoid State’ Revisited.” The American journal of medicine. Accessed October 29, 2023. <https://pubmed.ncbi.nlm.nih.gov/3898837/>.

Allen, W. Douglas. “Information Sharing During the Klondike Gold Rush.” The Journal of Economic History, 2005. 1-24. Pg. 9

“An Early Slot Machine.” National Parks Service, August 23, 2019.

<https://www.nps.gov/klgo/learn/historyculture/slot-machine.htm>.

Archibald, Margaret. 2006. “26.” Parks Canada - Canadian Historic Sites: Occasional Papers in Archaeology and History No. 26. <http://parkscanadahistory.com/series/chs/26/chs26-1g.htm>.

Auston, Julie-Anne. n.d. The Origins of Dogsled Mail in the Yukon in the 1890s.

<https://www.historymuseum.ca/cmhc/exhibitions/cpm/smail/sma>

AZ Animals Staff, “Caribou: Rangifer Tarandus,” AZ Animals, Flywheel Publishing, last modified April 4, 2023, <https://a-z-animals.com/animals/caribou/>.

Belinda Mulrooney - the richest woman in the klondike. National Postal Museum. (n.d.).

<https://postalmuseum.si.edu/exhibition/as-precious-as-gold-stories-from-the-gold-rush-extraordinary-women/belinda-mulrooney-the>

Berton, Pierre. Klondike: The Last Great Gold Rush: 1896-1899. Toronto: McClelland and Stewart, 1974.

“Big Pan-out : The Klondike Story. -- : Winslow, Kathryn : Free Download, Borrow, and Streaming.” Internet Archive, January 1, 1970.

<https://archive.org/details/bigpanoutklondik0000wins>.

Blair, Gwenda, Michael Lind, Jack Shafer, Zachary Karabell, Jeremy B. White, Sam Sutton and Carly Sitrin, and Bill Mahoney and Josh Gerstein. "The Man Who Made Trump Who He Is." POLITICO Magazine, August 25, 2015.

<https://www.politico.com/magazine/story/2015/08/the-man-who-made-trump-who-he-is-121647/>

Blair, Gwenda. *The trumps: Three generations that built an empire*. New York: Simon & Schuster, 2015.

By F. A. Peake\* - JSTOR. Accessed October 29, 2023.

<https://www.jstor.org/stable/pdf/43748488.pdf>.

"Canadian Pacific Railway Is Completed." Your Museum. Your Stories. Accessed October 17, 2023.

<https://www.historymuseum.ca/blog/canadian-pacific-railway-is-completed/#:~:text=On%20November%207%2C%201885%2C%20the,of%20the%20Canadian%20Pacific%20Railway.>

Charlene Porsild, "KEISH," in *Dictionary of Canadian Biography*, vol. 14, University of Toronto/Université Laval, 2003–, accessed October 31, 2023,

[http://www.biographi.ca/en/bio/keish\\_14E.html](http://www.biographi.ca/en/bio/keish_14E.html).

Chicago Record. 1986. *Klondike: The Chicago Record's Book for Gold Seekers : Profusely Illustrated*. N.p.: Desmond Pub.

"Chief Isaac's People of the River." Chief isaac's people of the river - the chiefs. Accessed October 26, 2023. [http://chiefisaac.com/the\\_chiefs.html](http://chiefisaac.com/the_chiefs.html).

"Common Lambsquarters Science Page," United States Botanic Garden, Cornell University, accessed October 20, 2023, <https://www.usbg.gov/sites/default/files/images/lambsquarter.pdf>.

"Contents." *chicagology*. Accessed October 17, 2023.

<https://chicagology.com/goldenage/1892telephone/>.

Dawson City, "Flora and Fauna."

Dawson City River Hostel, "Wildlife."

"Dawson: Physical Geography," Dawson City, accessed October 20, 2023,

<https://meiradawsoncity.weebly.com/chapter-2-physical-geography.html>.

Donnnan, Conor. “Mici Mac Gabhann - Irish Folklorist, Gold Miner, and Native American Ally.” Irish Central. Accessed November 7, 2023.

<https://www.irishcentral.com/roots/history/mici-mac-gabhann>.

“Environmental Consequences of the Gold Rush - Klondike Gold Rush National Historical Park (U.S.” 2018. National Park Service.

<https://www.nps.gov/klgo/learn/historyculture/environmental-impacts.htm>.

“Fish, Amphibians, Reptiles,” Hinterland Who’s Who, Canadian Wildlife Federation, accessed October 20, 2023, <https://www.hww.ca/en/wildlife/fish-amphibians-and-reptiles/>.

“Frank Laroche,” Everett Public Library, Accessed October 31, 2023,

<https://www.epls.org/257/Frank-LaRoche>.

“Frank Laroche,” Seattle Art Museum, Accessed October 31, 2023,

<https://art.seattleartmuseum.org/people/5232/frank-laroche;jsessionid=8F188F5D443452B353C6FC7D9BBB4041>.

“Fun With Flora and Fauna,” Dawson City, Klondike Visitors Association, accessed October 20, 2023, <https://dawsoncity.ca/flora-fauna/>.

Futurum. 2023. “Farming on permafrost - Futurum.” Futurum Careers.

<https://futurumcareers.com/farming-on-permafrost>.

“Gardening in Skagway (U.S. National Park Service).” National Parks Service. Accessed January 5, 2024. <https://www.nps.gov/articles/klgo-skagway-gardening.htm>.

Hal Guest, “Dawson,” The Canadian Encyclopedia, Historica Canada, March 4, 2015,

<https://www.thecanadianencyclopedia.ca/en/article/dawson>.

Hawtrey, R. G. “The Gold Standard.” The Economic Journal 29, no. 116 (1919): 428–42.

<https://doi.org/10.2307/2223352>. Pgs. 429-430.

Hayes, Adam. “Crime of 1873.” Investopedia, September 15, 2022.

<https://www.investopedia.com/terms/c/crime-1873.asp#:~:text=The%20Coinage%20Act%20of%201873,silver%20dollar%20was%20not%20included>.

Hetta Huskies. n.d. "Nutrition." Hetta Huskies. Accessed October 21, 2023.  
<https://www.hettahuskies.com/en/our-farm-dogs/our-dogs/nutrition>.

Gates, Michael, and Letters. "Chief Isaac: The Gentle Diplomat." Yukon News, July 21, 2017.  
<https://www.yukon-news.com/letters-opinions/chief-isaac-the-gentle-diplomat/>.

Gates, Michael. 2009. "Is Father Judge a forgotten hero?" Yukon News.  
<https://www.yukon-news.com/letters-opinions/is-father-judge-a-forgotten-hero/>.

"History of Dog Sledding." Hurtigruten Norwegian Coastal Express. Accessed October 29, 2023.  
<https://www.hurtigruten.com/destinations/norway/inspiration/attractions/history-of-dog-sledding/>.

"History." The Tlingit People. Accessed October 29, 2023.  
<https://thetlingitpeople.weebly.com/history.html>.

"History of the White Pass Trail - Klondike Gold Rush National Historical Park. 2020. (U.S.) National Park Service. <https://www.nps.gov/klgo/learn/historyculture/white-pass-history.htm>.

Hydraulic gold mining - history and current use. Accessed October 18, 2023.  
<https://mineralexpert.org/article/hydraulic-mining-placer-gold-monitor#:~:text=Hydraulic%20mining%20is%20easy%20and,and%20Alaska%20gold%20rush%20events>.

"Hydraulic Mining Techniques, California, 1870s." Hydraulic mining techniques, California, 1870s | U.S. Geological Survey. Accessed October 18, 2023.  
<https://www.usgs.gov/media/images/hydraulic-mining-techniques-california-1870s#:~:text=Hydraulic%20mining%20was%20a%20variation,the%20miners%20C%20ounces%20of%20gold>.

How to mine and prospect for Placer Gold. Accessed October 18, 2023.  
<https://web.archive.org/web/20120404213310/http://www.icmj2.com/BegCorner/USGSHowToMineForGold.htm#8517h10>.

"Iditarod Sled Dog Nutrition: Q&A with an Iditarod Veterinarian." Pet Food Institute, April 28, 2020.  
<https://www.petfoodinstitute.org/blog/iditarod-sled-dog-nutrition-qa-with-an-iditarod-veterinarian/>.



“How to Pan for Gold - Beginner Tips and Techniques.” How to Pan for Gold - Gold Prospecting Mining Equipment Detectors Snake Protection. Accessed January 5, 2024. [https://www.goldrushtradingpost.com/how\\_to\\_pan\\_for\\_gold](https://www.goldrushtradingpost.com/how_to_pan_for_gold).

Information sharing during the Klondike Gold Rush - Simon Fraser University. Accessed October 18, 2023. <https://www.sfu.ca/~allen/klondike.pdf>.

Introduction: Transportation in America and the carriage age. Accessed October 18, 2023. <https://parkcityhistory.org/wp-content/uploads/2012/04/Teacher-Background-Information.pdf>.

“Keish (Skookum Jim Mason) (U.S. National Park Service).” National Parks Service, February 10, 2020. <https://www.nps.gov/people/keish-skookum-jim.htm>.

Ken S. Coates, “Best Left as Indians: Native-White Relations in the Yukon Territory, 1840-1973,” McGill-Queen’s University Press, Accessed October 31, 2023, <https://www.mqup.ca/best-left-as-indians-products-9780773511002.php#:~:text=Native%2DWhite%20Relations%20in%20the%20Yukon%20Territory%2C%201840%2D1973&text=Ken%20Coates%20examines%20the%20interaction,and%20church%20and%20government%20policies>.

Konrad Taube, “Backcountry Uses for Medicinal and Edible Plants of the Yukon,” Wilderness Classroom, accessed October 20, 2023, <https://wildernessclassroom.org/backcountry-uses-for-medicinal-and-edible-plants-of-the-yukon/>.

Klondike Gold Rush capital punishment the convicted at former Fort Herchmer. Accessed October 29, 2023. [https://www.alaskaanthropology.org/wp-content/uploads/2017/08/akanth-articles\\_384\\_v10\\_n12\\_Mooney-Hare.pdf](https://www.alaskaanthropology.org/wp-content/uploads/2017/08/akanth-articles_384_v10_n12_Mooney-Hare.pdf).

“Klondike Gold Rush.” Dawson City.ca. Accessed October 25, 2023. <https://dawsoncity.ca/discover-dawson/klondike-gold-rush/>.

Klondike Gold Rush,” Historynet, accessed October 20, 2023, <https://www.historynet.com/klondike-gold-rush/#:~:text=Because%20of%20the%20harsh%20terrain,a%20long%20and%20arduous%20journey..>

“Klondike Gold Rush NHP: Legacy of the Gold Rush: An Administrative History of Klondike Gold Rush National Historical Park (Chapter 1).” National Parks Service. Accessed October 29, 2023.

[https://www.nps.gov/parkhistory/online\\_books/klgo/adhi/chap1.htm#:~:text=Most%20anthropologists%20consider%20that%20the,division%20of%20the%20Tlingit%20Indians.](https://www.nps.gov/parkhistory/online_books/klgo/adhi/chap1.htm#:~:text=Most%20anthropologists%20consider%20that%20the,division%20of%20the%20Tlingit%20Indians.)

Klondike. The Chicago Record's book for Gold Seekers. Accessed October 29, 2023.  
<https://archive.org/details/klondikechicagor00chic>.

“Klondike : The Last Great Gold Rush, 1896-1899 : Berton, Pierre, 1920-2004 : Free Download, Borrow, and Streaming.” Internet Archive, January 1, 1970.  
[https://archive.org/details/klondikelastgrea0000bert\\_m1g1/page/n9/mode/2up](https://archive.org/details/klondikelastgrea0000bert_m1g1/page/n9/mode/2up).

Ladue, S. (n.d.). Joseph Ladue and Joe Ladue - Yukon.  
<https://emrlibrary.gov.yk.ca/ebooks/joseph-and-joe-ladue-who-were-they.pdf>

Legends of america. Accessed October 29, 2023.  
<https://www.legendsofamerica.com/we-soapysmith/>.

MacLeod, R.C. 2019. “Sam Steele.” The Canadian Encyclopedia.  
<https://www.thecanadianencyclopedia.ca/en/article/sam-steele>.

“Martha Black: The American Socialite Who Went Hunting for Gold in the Yukon | CBC Canada 2017,” CBCnews, April 21, 2017,  
<https://www.cbc.ca/2017/canadathestoryofus/martha-black-the-american-socialite-who-went-hunting-for-gold-in-the-yukon-1.4079340>.

“Martha Black,” The Canadian Encyclopedia, August 5, 2008,  
<https://www.thecanadianencyclopedia.ca/en/article/martha-black>.

“Mary Hitchcock and Edith Van Buren - Klondike Tourists.” National Postal Museum. Accessed October 31, 2023.  
<https://postalmuseum.si.edu/exhibition/as-precious-as-gold-stories-from-the-gold-rush-extraordinary-women/mary-hitchcock-and>.

McLaughlin, Les. “Belinda Mulroney.” Yukon Nuggets. Accessed October 25, 2023.  
<https://yukonnuggets.com/stories/belinda-mulroney/>.

McLaughlin, Les. n.d. “Facts, Photos and News Radio.” Yukon Nuggets. Accessed October 21, 2023. <https://yukonnuggets.com/stories/the-starvation-winter/>.

McLaughlin, Les. "William Ogilvie." Yukon Nuggets. Accessed October 31, 2023.  
<https://yukonnuggets.com/stories/william-ogilvie/>.

"Milestones in U.S. Public Transportation History." APTA: Milestones in U.S. Public Transportation History. Accessed October 17, 2023.  
<https://web.archive.org/web/20090303212350/http://apta.com/research/stats/history/mileston.cfm>

"Mining the Miners." Bank of Canada Museum, June 24, 2016.  
<https://www.bankofcanadamuseum.ca/explore/exhibitions/past-exhibitions/temporary-exhibition-mining-the-miners/#:~:text=The%20Bank%20of%20British%20North,the%20Canadian%20Bank%20of%20Commerce.>

"Mountain Sheep," Hinterland Who's Who, Canadian Wildlife Federation, accessed October 20, 2023, <https://www.hww.ca/en/wildlife/mammals/mountain-sheep.html>.

"Murder in the Yukon- Part One," Yukon Nuggets, Accessed October 31, 2023,  
<https://yukonnuggets.com/stories/murder-in-the-yukon-part-one>.

Murray Lundberg, "Stampede Routes to the Klondike Gold," ExploreNorth, accessed October 20, 2023, [https://www.explorenorth.com/klondike/klondike-stampede\\_routes.html](https://www.explorenorth.com/klondike/klondike-stampede_routes.html).

"Nellie Cashman (U.S. National Park Service)." National Parks Service. Accessed October 26, 2023. <https://www.nps.gov/articles/000/nellie-cashman.htm>.

National Park Service, "Environmental Consequences."

"Nasnan- Meaning of Nasnan," Baby Names Pedia, Accessed October 31, 2023,  
<https://www.babynamespedia.com/meaning/Nasnan>.

"Ogilvie, William National Historic Person." Parks Canada Directory of Federal Heritage Designations. Accessed October 31, 2023.  
[https://www.pc.gc.ca/apps/dfhd/page\\_nhs\\_eng.aspx?id=1502](https://www.pc.gc.ca/apps/dfhd/page_nhs_eng.aspx?id=1502).

Pederson, Nathan. "Klondike Kate (1876-1957)." The Oregon Encyclopedia, July 20, 2022.  
[https://www.oregonencyclopedia.org/articles/klondike\\_kate/](https://www.oregonencyclopedia.org/articles/klondike_kate/).

Porsild, Charlene L. Gamblers and Dreamers: Women, Men, and Community in the Klondike. Vancouver: UBC Press, 1999. Pg. 98.

Porsild, Charlene. Klondike Family Life, September 29, 2005.  
file:///Users/christianallmand/Downloads/ebarsky,+1509-6226-1-CE.pdf.

Porsild, Charlene. n.d. "Biography – JOHNSON, LULU MAE – Volume XIV (1911-1920)." Dictionary of Canadian Biography. Accessed October 29, 2023.  
<http://www.biographi.ca/en/bio.php?BioId=41600>.

Robinson, Sally. 2010. "Humble Dreams: An Historical Perspective on Yukon Agriculture Since 1846."

"Rushing to the Grave (U.S. National Park Service)." National Parks Service. Accessed October 29, 2023.

<https://www.nps.gov/articles/klgo-death.htm#:~:text=Acts%20of%20violence%20also%20occurred,journey%20while%20in%20Dawson%20City>.

Sharer, Rachel. "The Great Klondike Gold Rush." Norman B. Leventhal Map & Education Center, August 16, 2021. <https://www.leventhalmap.org/articles/the-great-klondike-gold-rush/>.

"Shaaw Tláa (Kate Carmack)." The Canadian Encyclopedia, May 31, 2022.  
<https://www.thecanadianencyclopedia.ca/en/article/shaaw-tlaa-kate-carmack>.

"Staking Claims: The Gold Rush in Nineteenth-Century America." Who Was Marginalized | DPLA. Accessed October 29, 2023.

<https://dp.la/exhibitions/gold-rush/who-was-marginalized/native-americans>.

"Tagish." YNLC•Tagish. Accessed October 29, 2023.  
<https://web.archive.org/web/20070710053256/http://www.yukoncollege.yk.ca/ynlc/languages/tg/tg.html>.

"Telegraph History: Telecom-Milestones." telecom. Accessed October 17, 2023.  
<https://www.telecom-milestones.com/telegraph-historyblank#:~:text=From%201846%20private%20companies%20began,Atlantic%20telegraph%20line%20was%20completed>.

"Tlingit." Countries and Their Cultures. Accessed October 29, 2023.  
<https://www.everyculture.com/multi/Sr-Z/Tlingit.html#b>.

The Chicago Record (1897). Klondike. The Chicago Record's Book for Gold Seekers. Chicago: Chicago Records Co.

The Editors of Encyclopaedia Britannica, "Dawson," Britannica, Encyclopaedia Britannica, last modified October 23, 2023, <https://www.britannica.com/place/Dawson-Yukon>.

"The Gold Standard System." Gold Industry & Corporate. Accessed October 24, 2023. <https://www.gold.org/history-gold/the-classical-gold-standard>.

"The Klondike Gold Rush," Digital Collections, University of Washington Library, February 4, 2002, <https://content.lib.washington.edu/extras/goldrush.html>.

"The Klondike Gold Rush." :: The Klondike Gold Rush :: Accessed October 29, 2023. <https://content.lib.washington.edu/extras/goldrush.html>.

The Trump Family's Immigrant Story." History.com. Accessed October 26, 2023. <https://www.history.com/news/donald-trump-father-mother-ancestry>.

"The World of Science - Newspapers.ComTM." Newspapers.com, October 19, 1895. <https://www.newspapers.com/article/democrat-and-chronicle-the-world-of-scie/104163798/>.

Thesis - hightet - assets.yukonarchives.ca. Accessed October 29, 2023. <http://assets.yukonarchives.ca/189472.pdf>.

"Turbinia." What's On | Discovery Museum. Accessed October 17, 2023. <https://discoverymuseum.org.uk/whats-on/turbinia#:~:text=In%201894%20he%20built%20the,central%20hall%20at%20Discovery%20Museum>.

"Trails to the Klondike." National Postal Museum. Accessed January 5, 2024. <https://postalmuseum.si.edu/exhibition/as-precious-as-gold-stories-from-the-gold-rush-the-trails/t-rails-to-the-klondike>.

"Transcontinental Railroad - Construction, Competition & Impact." History.com. Accessed October 17, 2023. <https://www.history.com/topics/inventions/transcontinental-railroad>.

Transportation Revolution of the 19th century. Accessed October 18, 2023. <https://www.somersschools.org/cms/lib/NY01913963/Centricity/Domain/1252/American%20History%20-%20transportation%20revolution%20of%20the%2019th%20century.pdf>.

"Ton of Goods." National Parks Service. Accessed October 29, 2023. <https://www.nps.gov/klgo/learn/historyculture/tonofgoods.htm>.

University of Washington, “The Klondike Gold Rush.”

Powell, James. *A History of the Canadian Dollar*. Ottawa: Bank of Canada, 2005. Pg. 33.

Poyner IV, Fred. “Journey to the Yukon: Passage Aboard the Steamships from Puget Sound to the Far North.” *The Filson Journal*, January 31, 2020.

<https://www.filson.com/blog/field-notes/yukon-journey-from-puget-sound/>.

Venessa Benne, Maurice Colpron, and Mike Burke, “Current Thinking on Dawson Range Tectonics and Metallogeny,” *EMR Library*, Government of Canada, July, 2010,

<https://emrlibrary.gov.yk.ca/ygs/MR/MR-2/Current%20thinking%20on%20Dawson%20Range%20Tectonics%20and%20Metallogeny.pdf>.

Weiser-Alexander, Kathy. 2021. “Soapy Smith – Bunko Man of the Old West – Legends of America.” *Legends of America*. <https://www.legendsofamerica.com/we-soapysmith/>.

Whitten, David O. “The Depression of 1893.” *EH.net*, August 14, 2001.

<https://eh.net/encyclopedia/the-depression-of-1893/#:~:text=By%201890%2C%20the%20US%20economy,produced%20in%20manufacturing%20and%20mining>.

“Wild Edible Plants of Yukon,” *Northern Bushcraft*, accessed October 20, 2023,

[https://www.northernbushcraft.com/guide.php?ctgy=edible\\_plants&region=yt](https://www.northernbushcraft.com/guide.php?ctgy=edible_plants&region=yt).

Winslow, Kathryn. *Big Pan-Out: The Klondike Story*. London: Travel Book Club, 1953.

“Wolf,” *Hinterland Who’s Who*, Canadian Wildlife Federation, accessed October 20, 2023,

<https://www.hww.ca/en/wildlife/mammals/wolf.html>.

“Women of the Gold Rush.” *National Parks Service*. Accessed October 29, 2023.

<https://www.nps.gov/klgo/learn/historyculture/women.htm>.

Yes, women participated in the gold rush - *JSTOR DAILY*. Accessed October 29, 2023.

<https://daily.jstor.org/yes-women-participated-in-the-gold-rush/>.

“Yukon Indians and the Gold Rush.” *Who Discovered the Klondike Gold?* Accessed October 29, 2023. <https://www.canadianmysteries.ca/sites/klondike/context/firstnationshistory/4381en.html>.

“Yukon Territory Food and Drink,” World Travel Guide, Columbus Travel Media Ltd., accessed October 20, 2023,

<https://www.worldtravelguide.net/guides/north-america/canada/yukon-territory/food-and-drink/>;

“Traditional Plants Community Info Session in Dawson City,” First We Eat, April 15, 2017,

<https://firstweeat.ca/2017/04/15/traditional-plants-community-info-session-in-dawson-city/>.

“Yukon Wildlife Information,” Dawson City River Hostel, Yukon Hostels, accessed October 20, 2023, [https://www.yukonhostels.com/new\\_wildlife.html](https://www.yukonhostels.com/new_wildlife.html).



## CHARACTERS

*An asterisk indicates the character is fictional. To study the character, you may research elements the character represents or was involved in.*

### Skookum Jim (Keish) - Founder of the Klondike Gold Rush

Keish, also known as Skookum Jim Mason, was arguably the reason the Klondike Gold Rush began. He was born to a Tlingit father and a Tagish mother within the Dakl'aweidi (Killer Whale) Clan, and his deep clan connections gave him a strong sense of maintaining family and working together.<sup>123</sup> He often worked on the Chilkoot Trail as a packer, earning the nickname Skookum (strong) for how much he could carry at one time.<sup>124</sup> Later on, he, his sister Shaaw Tlaá, and her husband, George Carmack began prospecting for gold, having heard murmurs of undiscovered gold in the Klondike. Eventually, the trio found a vast, unexplored goldmine.<sup>125</sup> With this discovery, the Klondike Gold Rush began.

Skookum Jim himself lived a comfortable life after the discovery. Collectively, the trio earned around one million dollars and were essentially set for life.<sup>126</sup> He had trouble adapting to this lifestyle at first, having grown up from very humble beginnings. He first decided to build a large house for his family at Carcross, ensuring that they would all live safely and comfortably.<sup>127</sup> Now, he travels across the Klondike, overseeing many of the new towns and their development.

---

<sup>123</sup> “Keish (Skookum Jim Mason) (U.S. National Park Service).” National Parks Service, February 10, 2020. <https://www.nps.gov/people/keish-skookum-jim.htm>.

<sup>124</sup> Ibid

<sup>125</sup> Ibid

<sup>126</sup> Ibid

<sup>127</sup> Charlene Porsild, “KEISH,” in *Dictionary of Canadian Biography*, vol. 14, University of Toronto/Université Laval, 2003–, accessed October 31, 2023, [http://www.biographi.ca/en/bio/keish\\_14E.html](http://www.biographi.ca/en/bio/keish_14E.html).



<sup>128</sup> As one of the founders of the Klondike Gold Rush, he has unofficial authority in Dawson City that many will follow, and he has the funds to back his statements up. He is a generous figure and is deeply concerned not only with the development of the town but ensuring everyone there, like his family, can live safely and comfortably. His primary goal, however, is ensuring the continued existence of the Gold Rush, as the longer the Gold Rush occurs, the more notoriety he gains, and the more his fame grows.

### Shaaw Tláa (Kate Carmack) - Founder of the Klondike Gold Rush

As one of the members of the party that discovered gold in the Klondike, Shaaw Tláa (pronounced Shaw Claw) has been involved in the Klondike Gold Rush since the beginning. Born in 1857 in the Yukon, Shaaw is the sister of Keish (Skookum Jim) and a member of the Tagish First Nation in the dakl'aweidí (killer whale) clan.<sup>129</sup> She lives with her white American husband, George Carmack, in a cabin off of Bonanza Creek, where she tends to her daughter, takes care of laundry, and keeps the house in order. After she discovered the gold, Shaaw and George made a living by selling their gold, but Shaaw also sold homemade moccasins and winter clothing to miners. Shaaw hopes to continue to provide for incoming prospectors and potentially grow a business and build her income off of it, as well as remain within the Klondike region with her clan in hopes of living a calm and peaceful life with her family. She also hopes to support the rights of the indigenous groups within the region, especially for the Tagish First Nation, and ensure that they are not ignored in the future development of Dawson City.

---

<sup>128</sup> Ibid

<sup>129</sup> “Shaaw Tláa (Kate Carmack).” The Canadian Encyclopedia, May 31, 2022. <https://www.thecanadianencyclopedia.ca/en/article/shaaw-tlaa-kate-carmack>.

### Joseph Ladue - Founder of Dawson City

Joseph Ladue, who was responsible for building Dawson's saloon and sawmill, is credited with much of the development of Dawson City. He was born in New York but then moved west to search for gold. After unsuccessfully prospecting, he was one of the first to arrive in Klondike. When Ladue first arrived in what would become known as Dawson City, he had the foresight to buy multiple acres of land that he would later sell to stampeders so they could build businesses for the town. Because of his contributions, Ladue is known as the “founder of Dawson City”. As Dawson’s founder, he wants to continue to grow and develop the town, turning it into a lively and exciting city.<sup>130</sup> He also has a goal to elevate the steamboat and water transportation business of Dawson City, believing that with the development of an efficient port system through steamboat usage, Dawson City can truly thrive.<sup>131</sup>

### William Ogilvie - Land Surveyor

William Ogilvie is a very important figure in the prospecting business. Miners needed to map the gold fields and claims that were present in the region, and Ogilvie was able to do it. Born in Ottawa, he has a history of mapping the borders between the United States and Canada and ensuring these borders were precisely followed.<sup>132</sup> He had a close connection with George Carmack and was one of the first people contacted when Carmack, along with Skookum Jim and Kate Carmack, found gold in the Yukon. He was responsible for mapping out the streets of the

---

<sup>130</sup> Ladue, S. (n.d.). Joseph Ladue and Joe Ladue - Yukon.

<https://emrlibrary.gov.yk.ca/ebooks/joseph-and-joe-ladue-who-were-they.pdf>

<sup>131</sup> Poyner IV, Fred. “Journey to the Yukon: Passage Aboard the Steamships from Puget Sound to the Far North.” The Filson Journal, January 31, 2020. <https://www.filson.com/blog/field-notes/yukon-journey-from-puget-sound/>.

<sup>132</sup> McLaughlin, Les. “William Ogilvie.” Yukon Nuggets. Accessed October 31, 2023. <https://yukonnuggets.com/stories/william-ogilvie/>.

town Forty Mile, before mapping out Dawson City itself.<sup>133</sup> His work was known to be so comprehensive and thought-out that many of the problems within Alaska during this time, such as the high criminality rate and the failing of Boom Towns, were completely avoided in Canadian towns such as Dawson.<sup>134</sup> Ogilvie cared greatly about Canada and ensuring that the Klondike Gold Rush was handled safely and efficiently, even hoping to enter politics to accomplish this goal.<sup>135</sup> Now, Ogilvie primarily works to map out the Yukon region and expand Dawson City's territory. He works with the others in the committee to ensure that Dawson City is properly developed, and operates as an expert regarding the land claims of the prospectors and the town itself.

#### Soapy Smith - Businessman and Con Artist

Jefferson Randolph "Soapy" Smith II is a con artist and gangster.<sup>136</sup> He was born in 1860 in Newnan, Georgia. His family was wealthy and educated; however, his family lost their fortune and moved to Texas. Soon after, Soapy began to make his living by conning people. His most famous con, which earned him the nickname Soapy, was called the "Prize Package Soap Sell." He would wrap bars of soap in paper, however, he would wrap one bar with a \$100 bill under the paper. He would "mix" the \$100 soap with the rest, sell the soaps to people with the promise of a chance to win the cash prize, and give the \$100 soap to people he planted in the audience to maximize profits. With the success of his smaller cons, he began to participate in larger scams,

---

<sup>133</sup> Ibid

<sup>134</sup> Ibid

<sup>135</sup> "Ogilvie, William National Historic Person." Parks Canada Directory of Federal Heritage Designations. Accessed October 31, 2023. [https://www.pc.gc.ca/apps/dfhd/page\\_nhs\\_eng.aspx?id=1502](https://www.pc.gc.ca/apps/dfhd/page_nhs_eng.aspx?id=1502).

<sup>136</sup> Weiser-Alexander, Kathy. 2021. "Soapy Smith – Bunko Man of the Old West – Legends of America." Legends of America. <https://www.legendsofamerica.com/we-soapysmith/>.

including fake lotteries and stocks. He would build a criminal empire, moving from town to town with his “soap gang.” He kept control by keeping officials on his payroll, targeting tourists instead of locals, and making large donations to city charities.<sup>137</sup> Having been recently run out of Denver, Soapy is setting his eyes toward Dawson City and its many opportunities. He hopes to reestablish his crime empire, gain control of the boomtown, and further build his fortune.

### Sam Steele - Policeman of the Canadian North-West Mounted Police

Samuel Benfield Steele is a Canadian Mounted policeman, born January 1848 in London, England.<sup>138</sup> Taking after his father, Steele had wanted to become a soldier from an early age. He enlisted in his local militia in his teens, rising in the ranks to Corporal. In 1873 When the Canadian government first established the Mounted Police, Sam Steele was one of the first to enlist as a Sergeant Major. He maintained order in the workforce during the building of the Canadian railway, taking his job incredibly seriously, crushing any potential workers’ revolt.<sup>139</sup> He served during the North-West Rebellion before he was called back to Calgary. He established Fort Steele and resolved relations when there was tension between the Canadian government and First Nation people.<sup>140</sup> He has now been deployed to Dawson City, where he has established that prospectors must bring rations with them on their journey. His objectives have been laid out to him by his superiors: Establish order in the chaos, keep the streets clean of crime, and convince Americans (by diplomacy or force) that this northern territory was strictly *Canadian*.<sup>141</sup>

---

<sup>137</sup> (Weiser-Alexander 2021)

<sup>138</sup> MacLeod, R.C. 2019. “Sam Steele.” The Canadian Encyclopedia. <https://www.thecanadianencyclopedia.ca/en/article/sam-steele>.

<sup>139</sup> McLaughlin, Les. n.d. “Facts, Photos and News Radio.” Yukon Nuggets – Facts, Photos and News Radio. Accessed October 29, 2023. <https://yukonnuggets.com/hougens-history/samuel-benfield-steele>.

<sup>140</sup> (MacLeod 2019)

<sup>141</sup> (McLaughlin, n.d.)

Andrea “Andy” Kaminski\* - American Ambassador and Policewoman

Andrea Kaminski represents the American side of policing within the Klondike. She was born to Polish immigrants in the United States, escaping persecution within Eastern Europe, and grew up in Seattle. As a kid, she was often responsible for helping maintain her parents’ bakery store and thus learned how to bake for herself, as well. This maintenance included not only running the store but also making sure her family was safe from robbery or violence. She had goals to join the police department, but as women were not allowed to join, she taught herself self-defense and other necessary skills for protection. When she was 33 years old, the Klondike Gold Rush began. She and her lover, a man named Lucas Taylor, traveled to Skagway in Alaska to join the rush, but Lucas died on the way there. She quickly earned a reputation in Skagway as someone not to be messed with, before city leadership approached her and asked if she would like to travel to Dawson City to represent American interests, as they were worried about the city’s increasing influence. Now, she serves in committee as a voice for the American side of the Gold Rush, and a de facto force of justice, even though opposition rises commonly with Canadian law enforcement. She also wants to ensure Dawson’s safety, so travelers can feel comfortable coming to the area.

### Jack London - Acclaimed Author and Journalist

Jack London is a prolific author best known for his novel “The Call of the Wild.” Originally from San Francisco, he came from a working household and worked through his childhood. At the age of fifteen, he was a member of a gang of oyster pirates, poaching oysters and selling them for high prices, making more than he did at his above-board cannery job, though he was sent to jail for some time due to his illegal activities. He then traveled for a few years on a seal-hunting boat to Japan and the Bonin Islands before the age of twenty.<sup>142</sup> In 1897, he went north looking for gold and adventure. The journey there was grueling, and London wrote about it vividly in many accounts. He stayed one winter in the Klondike, which one could argue helped his career take off due to the amount of inspiration he gained from his stay. His views often contradicted each other, jumping from ideology to ideology even through consecutive works. Still, he was outspoken and liberal, and quite often in the news, talking about economics, politics and speaking out against injustice.<sup>143</sup>

### William Judge - Town Priest and Volunteer

Father William Judge was born in Maryland in April 1850. He was born in a religious family, with all four of his siblings and himself pursuing careers in religion. When he was 25 years old, Judge started his religious training under the Roman Catholic Jesuit order. In 1890 he volunteered his services to Alaska. In a few years, he acquired the skills of a carpenter,

---

<sup>142</sup> Kenneth Brandt, “The Short, Frantic, Rags-to-Riches Life of Jack London,” Smithsonian Magazine, Updated December 14, 2016,

<https://www.smithsonianmag.com/smithsonian-institution/short-heroic-rags-riches-life-jack-london-180961200/>.

<sup>143</sup> “Jack London,” Jack London State Historic Park, Accessed October 31, 2023,

<https://jacklondonpark.com/jack-london-biography/>.

cabinet-maker, blacksmith, and baker. He built his own church and learned the native language to help his teachings.<sup>144</sup> He has now been reassigned to Dawson City. With his experience in the Alaskan climate and his knowledge of carpentry, he hopes he can help build a flourishing community in Dawson City and spread his religious teachings.

#### Dr. Malerie Pracktiss\* - Town Doctor

Dr. Malerie Pracktiss came to Klondike with nothing but the clothes on her back and a thirst for innovation. Carrying with her a suitcase of top-of-the-line (for the era) medical equipment, she has one of the very few medical practices in Dawson running out of her humble shed. Despite men in the area having qualms with a woman being their doctor, they most frequently have no choice but to turn to her as she charges the least for her work. Other doctors with a smaller clientele raise the issue of her work being equivalent to her cheap prices, and on a few occasions, have contested her expertise. Despite this and her unnoticed efforts, the survival rate of her patients is still significantly low. For this reason, she calls upon investors and prospectors of Dawson to put modern technological innovation at the top of their priorities, not just for her own interest but for her survival. She is an advocate for the public health of Dawson, but not at the expense of her profit margins. She's fickle and difficult to negotiate with unless what one can offer furthers her mission. Little is known about her origins or why she came to Dawson in the first place.

---

<sup>144</sup> Gates, Michael. 2009. "Is Father Judge a forgotten hero?" Yukon News. <https://www.yukon-news.com/letters-opinions/is-father-judge-a-forgotten-hero/>.

### Chief Isaac - Leader of the Hän Peoples

As a leader of the Hän people of the Klondike region, Chief Isaac has been a prominent liaison between the indigenous peoples of the Klondike and the prospectors. Calm and resolute, Chief Isaac has welcomed the prospectors to their land in the Yukon but has made the message clear to the travelers that the land that they mine from and live on belongs to the natives.<sup>145</sup> Moreover, Chief Isaac has found new responsibilities since the gold rush as the representative of his people at festivals, meetings, and celebrations, often conducting moving speeches.<sup>146</sup> In the end, Chief Isaac hopes that his duty as a diplomat between the Hän people and the foreign prospectors will lead to the preservation of the native land, the conservation of local wildlife, and the retention of Hän culture in the region.

### Nasnan\* - Hän Activist and Feminist

The name Nasnan means “surrounded by a song.”<sup>147</sup> A native Hän woman activist, Nasnan was very vocal about her opposition to how the indigenous people were being treated and how the gold seekers were treating the land. She often found herself at odds with Chief Issac, feeling that his methods of retreating were too passive, though they also had their agreements. When her clan moved several miles downriver, she did not follow, opting to remain in a more solitary place between Dawson City and her clan’s new settlement to try to fight for her people’s rights. Many natives found a compromise with the newcomers to be the best method

<sup>145</sup> Gates, Michael, and Letters. “Chief Isaac: The Gentle Diplomat.” Yukon News, July 21, 2017. <https://www.yukon-news.com/letters-opinions/chief-isaac-the-gentle-diplomat/>.

<sup>146</sup> “Chief Isaac’s People of the River.” Chief isaac’s people of the river - the chiefs. Accessed October 26, 2023. [http://chiefisaac.com/the\\_chiefs.html](http://chiefisaac.com/the_chiefs.html).

<sup>147</sup> “Nasnan- Meaning of Nasnan,” Baby Names Pedia, Accessed October 31, 2023, <https://www.babynamespedia.com/meaning/Nasnan>.



of adaptation and survival,<sup>148</sup> but Nasnan saw the exclusion, mistreatment, and exploitation of the local population and took a different approach. She could often be found protesting in the streets, which landed her in legal trouble more than once. She narrowly avoided execution, but unfortunately, some who supported her were not as lucky.<sup>149</sup> This further served to cement her dislike for the gold rushers.

### Kathleen “Klondike Kate” Rockwell - Prolific Entertainer

Kathleen Eloisa “Kitty” Rockwell, also known as Klondike Kate, made her name and fortune working as a vaudeville singer and dancer within Dawson City, becoming one of the most prominent entertainers there. She was born in Junction City, Kansas, in 1876 and went from place to place, taking different jobs, notably as a background dancer.<sup>150</sup> Eventually, she heard rumors of the Klondike Gold Rush and decided to follow, hoping to make a career for herself. The process of getting to Dawson City was a difficult one, and it is alleged that she had to dress in men’s clothing even to be allowed access, as there were tight restrictions to get into the area. Once she arrived, she took more entertainment jobs before stabilizing with the Savoy Theatrical Company.<sup>151</sup> She developed a trademark act known as the “Flame Dance” in which she wore a long and sequined red dress which she would dance to recreate an illusion of fire.<sup>152</sup> Rockwell

---

<sup>148</sup> Ken S. Coates, “Best Left as Indians: Native-White Relations in the Yukon Territory, 1840-1973,” McGill-Queen’s University Press, Accessed October 31, 2023, <https://www.mqup.ca/best-left-as-indians-products-9780773511002.php#:~:text=Native%2DWhite%20Relations%20in%20the%20Yukon%20Territory%2C%201840%2D1973&text=Ken%20Coates%20examines%20the%20interaction.and%20church%20and%20government%20policies>.

<sup>149</sup> “Murder in the Yukon- Part One,” Yukon Nuggets, Accessed October 31, 2023, <https://yukonnuggets.com/stories/murder-in-the-yukon-part-one>.

<sup>150</sup> Pederson, Nathan. “Klondike Kate (1876-1957).” The Oregon Encyclopedia, July 20, 2022. [https://www.oregonencyclopedia.org/articles/klondike\\_kate/](https://www.oregonencyclopedia.org/articles/klondike_kate/).

<sup>151</sup> Ibid

<sup>152</sup> Ibid

developed a small fortune and maintained a lucrative entertainment career in Dawson City. She wants the city to grow in popularity, as the more people there, the more customers she can provide for. Additionally, her difficult experience getting to Dawson may want her to advocate for more efficient and traveler-friendly methods of getting to the Klondike.

### Fred Trump - Hopeful Entrepreneur

Born in Germany in 1869, Frederick Trump is an immigrant to the Americas to escape the German army's conscription laws and pursue a new life as a businessman.<sup>153</sup> He moved from Germany to New York City, where he lived with his relatives before moving to Seattle six years later.<sup>154</sup> In Seattle, Trump opened a restaurant named "the Dairy Restaurant," where he would build his wealth before selling the restaurant three years later and moving to the gold rush town of Monte Cristo, Washington.<sup>155</sup> Trump opened a boarding house in the city for gold miners to live in and pay him for rent. However, prospectors began fleeing from the town once they realized the amount of nearby gold was less than expected, signaling Trump to look elsewhere to make more money. Noticing the Klondike Gold Rush, he set his eyes on the region, sending two miners to claim land in the Klondike and mine gold for him. Trump hopes to put his Klondike business plans to fruition by opening hotels, restaurants, and brothels to make more money in the Klondike than in Monte Cristo.

---

<sup>153</sup> "The Trump Family's Immigrant Story." History.com. Accessed October 26, 2023. <https://www.history.com/news/donald-trump-father-mother-ancestry>.

<sup>154</sup> Blair, Gwenda. *The trumps: Three generations that built an empire*. New York: Simon & Schuster, 2015.

<sup>155</sup> Blair, Gwenda, Michael Lind, Jack Shafer, Zachary Karabell, Jeremy B. White, Sam Sutton and Carly Sitrin, and Bill Mahoney and Josh Gerstein. "The Man Who Made Trump Who He Is." POLITICO Magazine, August 25, 2015. <https://www.politico.com/magazine/story/2015/08/the-man-who-made-trump-who-he-is-121647/>.

### Nellie Cashman - Businesswoman and Restaurant Owner

If one could describe the life of Ellen “Nellie” Cashman, it would be a life filled with adventure. Born in Midleton, Ireland, in 1845, Nellie emigrated to the United States due to the Irish Potato Famine, settling in Boston in the 1850s.<sup>156</sup> By the mid-1860s, Nellie moved with her family out west to San Francisco. While the rest of her family settled down in San Francisco and her sister married, Nellie wanted more and chose not to get married, stating that she “hasn't had time for marriage” and “men are a nuisance anyhow, now aren't they? They're just little boys grown up.” Nellie then moved to Pioche, Nevada, where she would start her own boarding houses and restaurants in gold rush towns such as Tombstone, Arizona. Nellie became largely successful with these businesses, and noticing her success looked towards other gold rush towns. She eventually settled on Dawson City, opening a restaurant in the town and purchasing a gold claim. Nellie hopes to continue her business endeavors in Dawson City and manage even more businesses later in the life of Dawson City.

### Frank La Roche - Photographer

Frank La Roche was born in Philadelphia. Growing up, he learned the art of photography and ended up moving to Seattle after the Great Fire of Seattle. Though the city was in ruins, he managed to open a gallery where he took high-end portraits and scenic photographs. Later, he would travel to California along the west and take the Canadian Pacific Railway to take more scenic views. He would then go to the Yukon to take photos of his journey through the Chilkoot Pass, selling them to those he encountered on his travels. He is well known for the photos he

---

<sup>156</sup> “Nellie Cashman (U.S. National Park Service).” National Parks Service. Accessed October 26, 2023. <https://www.nps.gov/articles/000/nellie-cashman.htm>.

took of the native people, being one of the few to do so.<sup>157</sup> In fact, the representation he gave the native people through his photographs made him popular with them. In Dawson City, La Roche wants to keep a log of history through his photographs, while also working to provide recognition to the indigenous populations.<sup>158</sup> In committee, he strives for these goals while also using his photography skills as a method of journalism and information sharing with the people of Dawson City.

### Lulu Mae Johnson - Dancer

Lulu Mae Johnson was born in Alabama in 1877. She is touted as being extremely beautiful and talented, which led her to be highly respected in her life as a performer.<sup>159</sup> She never stays in one place for long. Her free-spirited attitude towards business and her love of the tavern has led her to trouble with the police in the past. Her involvement in underground entertainment has led her to have multiple warrants for her arrest. She is currently part of a performing dance troupe, going wherever the money flows with ambitions of owning her own troupe or business. Her troupe is headed to the current biggest cash flow west of the Mississippi: Dawson City. She plans to grow her own career and take full advantage of the business opportunities in the new city, to own her own entertainment business. Additionally, however, she dislikes the elitist position many other entertainers have taken with Dawson City and strives to break that mold as an entertainer who represents the common people and works to ensure they

---

<sup>157</sup> “Frank Laroche,” Seattle Art Museum, Accessed October 31, 2023, <https://art.seattleartmuseum.org/people/5232/frank-laroche.jsessionid=8F188F5D443452B353C6FC7D9BBB4041>.

<sup>158</sup> “Frank Laroche,” Everett Public Library, Accessed October 31, 2023, <https://www.epls.org/257/Frank-LaRoche>.

<sup>159</sup> Porsild, Charlene. n.d. “Biography – JOHNSON, LULU MAE – Volume XIV (1911-1920).” Dictionary of Canadian Biography. Accessed October 29, 2023. <http://www.biographi.ca/en/bio.php?BioId=41600>.

have equal access to fun within the city. Dawson City is her place to not only make a name for herself but also support others like herself, who came from nothing and worked their way upwards.

### Belinda Mulrooney - Wealthy Business Opportunist

Belinda Mulrooney is a very important figure in Dawson City and was known as the “richest woman in Klondike.” Belinda immigrated to the United States from Ireland when she was a child and went north to the Yukon after the discovery of gold. She made her initial earnings in Klondike by up-selling goods she purchased earlier to desperate prospectors in Dawson. She invested the money she made from that into a hotel which gave her the profits to buy mining claims to hire workers to mine them. Mulrooney wants to continue to increase her wealth in Klondike. Mulrooney is very valuable to the political activity in Dawson because of her vast business knowledge and hopes to advise the town on economic matters.<sup>160</sup>

### Martha Black - Industrialist Entrepreneur

Martha Black was an American socialite who, like many others, moved to the Klondike hoping to grow her wealth. Back at home, she felt disconnected from the world around her and was upset with her husband’s sudden decision to not join her on the road to the Klondike, so she wanted to prove that she could become successful without him. Martha was pregnant with a son on her journey there, and shortly after she gave birth, she started up a business staking gold

---

<sup>160</sup> *Belinda Mulrooney - the richest woman in the klondike*. National Postal Museum. (n.d.). <https://postalmuseum.si.edu/exhibition/as-precious-as-gold-stories-from-the-gold-rush-extraordinary-women/belinda-mulrooney-the>

claims on Excelsior Creek.<sup>161</sup> She quickly realized that the claims of promised gold that was supposedly abundant were greatly exaggerated. She was quite rich, with her ability to afford to make much of the journey by steamboat and hire porters to carry her year's worth of supplies for her, which alleviated her squashed expectations. Martha was quite outspoken and independent, and would later take an interest in politics.<sup>162</sup> Martha hopes to expand the industrialization of the Klondike and grow her fortune by utilizing the local resources, while also working to improve her political image.

### Micí Mac Gabhann - Irish Indigenous Ally

As a Gaelic man who grew up under the oppression of Britain's colonial might, Micí Mac Gabhann found himself as an ally of the indigenous peoples of the Klondike due to their mirrored experiences. Born in Ireland in 1865 and moving to Scotland, Gabhann spent most of his youth in the British Isles on a potato farm before moving to the United States in the 1880s.<sup>163</sup> In the United States, he worked in the mines of Montana before the Klondike Gold Rush. While in Montana, he witnessed firsthand the removal of the indigenous peoples from their homelands, which fueled his already existing anti-colonial sentiments. As soon as gold was discovered in the Klondike and many prospectors moved to Dawson City, he followed along, hoping to grow his wealth with the prospectors. However, he is not concerned with growing Dawson City, feeling

---

<sup>161</sup> "Martha Black: The American Socialite Who Went Hunting for Gold in the Yukon | CBC Canada 2017," CBCnews, April 21, 2017, <https://www.cbc.ca/2017/canadathestoryofus/martha-black-the-american-socialite-who-went-hunting-for-gold-in-the-yukon-1.4079340>.

<sup>162</sup> "Martha Black," The Canadian Encyclopedia, August 5, 2008, <https://www.thecanadianencyclopedia.ca/en/article/martha-black>.

<sup>163</sup> Donnan, Conor. "Micí Mac Gabhann - Irish Folklorist, Gold Miner, and Native American Ally." Irish Central. Accessed November 7, 2023. <https://www.irishcentral.com/roots/history/mici-mac-gabhann>.

solidarity with the local indigenous people, stating that they should maintain their "attachment to the land of their ancestors" and "keep their customs and habits without interference from the white man."

### Edith Van Buren - Thrillseeking Tourist

Edith Van Buren was the utmost example of a tourist within the Klondike. She was a wealthy socialite who loved to travel and also happened to be a descendant of previous president Martin Van Buren. This gave her political connections, which assisted her in her travels, which included venturing to China and Egypt.<sup>164</sup> When word spread of gold in the Klondike, she and her friend Mary Hitchcock, another wealthy socialite, took off for Dawson City. They brought with them many fineries that prospectors did not have, including air mattresses, books, fine linen, elegant clothes, a portable bowling alley, a gramophone, and an ice-cream freezer.<sup>165</sup> They also brought their pet dogs and an exorbitant amount of birds.<sup>166</sup> This excessive packing and eccentric desire to venture into the Klondike made many in their current home of San Francisco doubt their ability, but this did not deter the two. Within a few weeks, much earlier than most trips to the Klondike as they took what was nicknamed "The Rich Man's Route" involving a steamship avoiding most of the treacherous travel, they made it to Dawson City.<sup>167</sup> They were initially guests at Belinda Mulroney's Fair View Hotel before building up tents for themselves and

---

<sup>164</sup> "Mary Hitchcock and Edith Van Buren - Klondike Tourists." National Postal Museum. Accessed October 31, 2023.

<https://postalmuseum.si.edu/exhibition/as-precious-as-gold-stories-from-the-gold-rush-extraordinary-women/mary-hitchcock-and>.

<sup>165</sup> Ibid.

<sup>166</sup> Ibid.

<sup>167</sup> Ibid.

creating a limited-time home.<sup>168</sup> Now, Van Buren and Hitchcock live together and work with the other residents of Dawson City to make it safer for everyone to travel to and develop the city to a point where it can stand on its own.

### Annie Hall Strong - Women's Journalist

Annie Hall Strong is a journalist who, like many other women of the time, accompanied her husband to discover what all the fuss was about Klondike Fever. Before she came, however, she earned her notoriety by writing an article titled "Advice to Women" which detailed the brutality of the journey to Klondike and what one might need to survive as a woman.<sup>169</sup> Before this, she was mostly a romance novelist. Her advice led to most women provisioning before they even left their hometowns and is thereby responsible for women having a higher chance of survival in Dawson than men. Her husband, John Franklin Alexander Strong, is a Canadian printer who has connections to American and Canadian journalists and the printing press industry. Annie wishes to document the wiles of Klondike Fever as an examination of human strength and especially prioritizes getting any stories of the like back out into America.

### Sergei Ivanovich Zarnovsky\* - Dogsled Trainer

"Swift" Sergei Ivanovich Zarnovsky came to the Yukon at age nine with his parents. At age twenty, the United States purchased Alaska from the Russian Empire, and he simply decided to stay in the region. He found work as a sled dog trainer at age fifteen and continued the

---

<sup>168</sup> Ibid.

<sup>169</sup> "Annie Hall Strong (U.S. National Park Service)." National Parks Service. Accessed November 1, 2023. <https://www.nps.gov/articles/000/annie-hall-strong.htm>.



business ever since the owner of the business and his parents died of typhoid. Zarnovsky has a unique bond with his dogs and believes he can communicate with them and understand their needs and emotions. He even fosters the dogs of other prospectors during the off-season when they have no use for them, breeding them without their knowledge of the new stampeders. He is extremely reliable, always delivering the mail on time by dog sled and gaining recognition from many others in Dawson, giving him the nickname of “Swift” Sergei. His feet are injured and, in some parts, amputated from multiple frostbite wounds. He believes the best way to traverse the Klondike is by dog sled and opposes any new technology that might hurt his business and the respect for the natural environment there. Sergei’s transportation knowledge proves him to be a very valuable asset for the future of Dawson City.

### Robert Service - Poet and Writer

Robert W. “Bard of the Yukon” Service was born on January 16th, 1874, in Lancashire, England. His father was also named Robert Service, and his middle name “William” came from his rich uncle. After Service’s rich uncle did not include him in his will, Service dropped the name in favor of just the initial. He began writing at an early age. It was said that he composed his first verse at only 6 years old. He has an extremely active social life and was incredibly popular, known for his biting wit. He has a strong passion for stories and poetry, whether creating or consuming them. He had even once challenged his university professor to a fight outside the classroom over an interpretation of Hamlet. The selling of his verses and writings had already become profitable. Critics did not always appreciate Service, and many dismissed his work as “doggerel” due to their popularity and how quickly they were written. Service does not

mind the criticisms, however, he does take offense to his verses being labeled as “poetry.” The British Isles can feel constraining after a couple of decades, and Service has always had a fondness for adventure, so he has just left for the West in pursuit of becoming a cowboy.<sup>170</sup> The suddenly booming town of Dawson City seems the finest place to hone his craft, pursue notoriety, and perhaps cozy up with the locals.

### Gladys Swiftwater\* - Schoolteacher

Gladys Swiftwater is a schoolteacher and role model to many children in Klondike. She hails from a small family on the east coast of America. She came to Klondike alongside her husband, William, but he died from what was believed to be a tragic case of dysentery just a few months after making the journey. With most of their assets being expended by the journey, she decided to make the most of what she had. With the education she received back home, she took to teaching the local children in her temporary housing. Since then, she has advocated for better public facilities for Dawson so the town's children would no longer have to resort to harsh labor and could be taught in a better environment. Despite morality not being at the top of the Klondike priority list, Ms. Swiftwater takes such matters very seriously for the sake of making Dawson a suitable environment for rapidly growing families. She is affiliated with the Presbyterian church and still has a significant amount of money from her husband's death that could assist in promoting this agenda.

---

<sup>170</sup> “About Robert W. Service | Academy of American Poets.” n.d. Poets.org. Accessed November 8, 2023. <https://poets.org/poet/robert-w-service>.